

MUTO Premium XL120

Sidelite mount with Dormotion and Self-close (Glass door)

Installation Manual

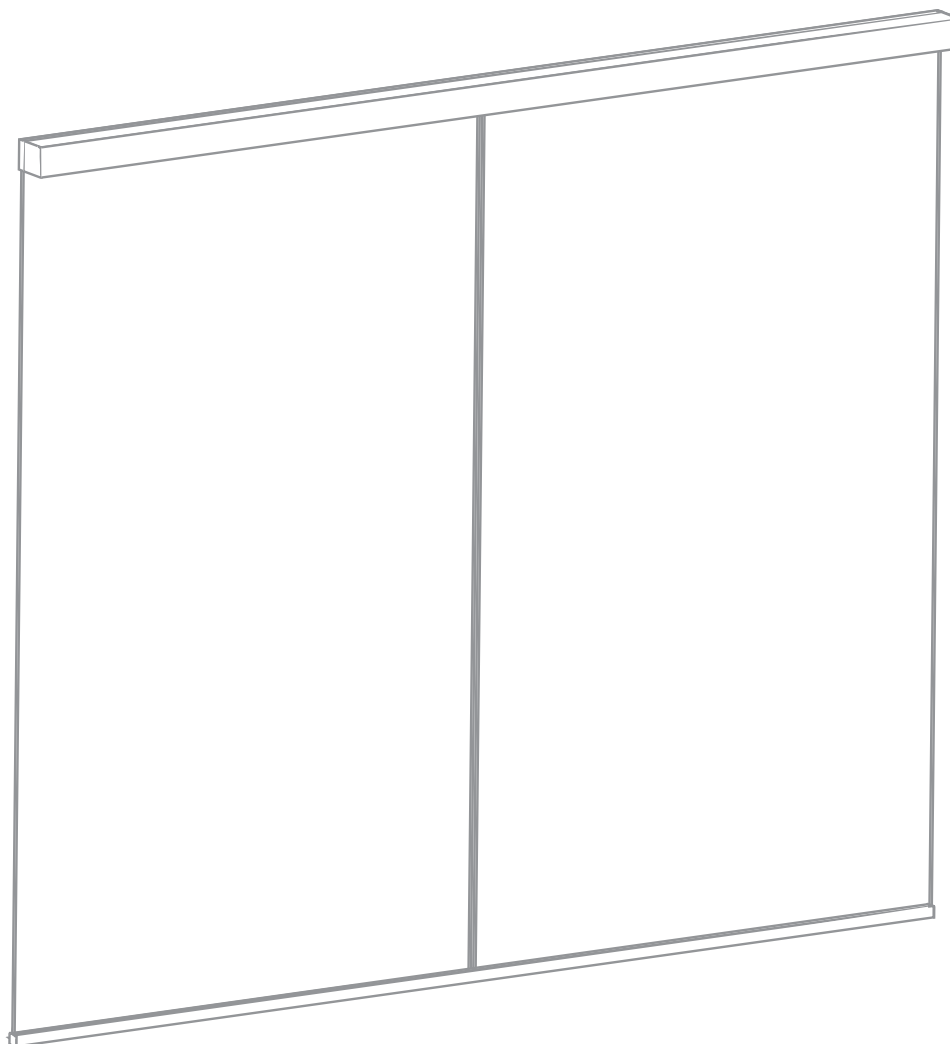

Table of contents

1	Technical specifications	3		
1.1	Overview	3	2.19	Install RH DORMOTION unit - door closed 17
1.1.1	General information	3	2.20	Install LH DORMOTION unit - door open 18
1.1.2	Intended use	3	2.21	Adjust start/stop pin height (if necessary) 19
1.1.3	Glass requirements and fittings	3	2.22	Self-close unit: Install self-close hold open clamp 19
1.1.4	Requirements for glass panel	3	2.23	Self-close unit: Install self-close hold open ball 20
1.1.5	Safety instructions	3	2.24	Self-close unit: Install self-close cable connector 20
1.1.6	Symbols used - Safety/Installation	3	2.25	Self-close unit: Install self-close cable unit 21
1.1.7	Maintenance, care, repair	3	2.26	Self-close unit: Prepare self-close cable unit 21
1.1.8	Disposal	3	2.27	Self-close unit: Adjust tension in self-close cable unit 22
1.2	Specifications - technical data	4	2.28	Install cover clips 23
1.3	Tempered laminate glass (TLG) and adhesive specifications	4	2.29	Cover spacers 23
2	Installation instructions	5	2.30	Install brush profile 24
2.1	Overall	5	2.31	Install view protection clips 24
2.2	Door/wall dimensions	6	2.32	Install cover and view protection profile 25
2.3	Installing the end stops	7	2.33	Install end caps 25
2.4	Securing track to mounting surface	8		
2.5	Securing sidelite section profile to track	8		
2.6	Installing U-channel for sidelite	9		
2.7	Installing sidelite glass	9		
2.8	Install sidelite glass filler panel	10		
2.9	Install sidelite glass gasket	10		
2.10	Disengaging the anti-jump	10		
2.11A	Installing roller carriers: on monolithic glass ONLY	11		
2.11B	Installing roller carriers: on tempered laminate glass ONLY	12		
2.12	Installing DORMOTION start/stop	13		
2.13	Install glass/rollers on track	14		
2.14	Install floor guide	14		
2.15	Install floor guide: continued	15		
2.16	Engaging the anti-jump	15		
2.17	Adjustment door height	15		
2.18	Adjustment end stop location: LEADING end stop	16		
	Adjustment end stop location: TRAILING end stop	16		

1 Technical specifications

1.1 Overview

These instructions are for installation of MUTO PREMIUM sliding door system XL120 for the following mounting and style versions:

1. Sidelite mount

1.1.1 General information

- dormakaba requires use of tempered monolithic or tempered laminated glass.
- dormakaba glass hardware is not suitable for application in rooms where chemicals (e.g. chlorine) are used as indoor swimming pools, saunas or salt-water pools.
- Never move sliding panels faster than walking speed and always stop the door manually before it reaches end position.
- Do not slide doors with excessive force. Install limiting stop to prevent door from opening too far.

1.1.2 Intended use

- For sliding door in dry indoor areas only
- For manual slowly opening and closing only

1.1.3 Glass requirements and fittings

- The substructure/wall must be able to bear permanent loads and be level (max. tolerance: 1/16" [2] per 39" [1m]).
- Fasteners must be sufficiently dimensioned for the substructure/wall and weight of the door.
- When adjusting glass components, always stick to the required clearance for the respective hardware. Adjust clearance so glass does not come in contact with any hard surfaces such as glass, metal or concrete.
- Do not use excessive force when installing the glass (avoid over tightening screws).

1.1.4 Requirements for glass panel

- dormakaba requires use of fully tempered glass, which complies with ASTM C 1036 and ASTM C 1048. Secondary heat soaking processes are recommended but not required. This applies to both tempered monolithic and tempered laminated glass.
- Clamping area must be flat and uncoated (no self-cleaning coating!)
- Never use glass with conchoidal fractures and/or damaged edges.

1.1.5 Safety instructions

- Installation requires two people.
- Only properly qualified and specially trained staff are authorized to mount dormakaba glass hardware.

- Due to crushing hazards and possible injury caused by breakage of glass during mounting, corresponding protective clothing (especially gloves and protective goggles) is required.
- Never clamp metal fitting hardware directly to glass surface.

1.1.6 Symbols used - Safety/Installation



CAUTION

Mounting components must meet the requirements of substructure/wall and door weight. Please read the technical information for fittings.



WARNING

Risk of breaking glass. When installing the door, support the door panel with a block of wood or similar object.



TIPS AND RECOMMENDATIONS

Information note



CLOSING EDGE

1.1.7 Maintenance, care, repair

- Immediately replace damaged parts.
- Always use original dormakaba parts.
- Clean clamping area with alcohol-based standard commercial cleaning agent before mounting the glass hardware.
- Use a damp clothe for occasional cleaning, especially the track.
- Always use silicone - and oil-free cleaners (e.g. acetone).
- Check glass hardware at regular intervals for proper positioning and smooth operation and correct adjustment.
- High traffic door systems require inspection by properly qualified staff (specialized companies or installation firms.)

1.1.8 Disposal

Disposal in accordance with local, state and national regulations.

1.2 Specifications - technical data

		Single Door	Double Door
		XL120	XL120
Ceiling mount	Door leaf weight lbs [kg]*	≤264lbs [≤120]	2 x ≤264lbs [2 x ≤120]

* Including weight of auxiliary hardware.

1.3 Tempered laminate glass (TLG) and adhesive specifications

Required parts for laminate glass with MUTO System (not included)	Part Number	Quantity	Usage recommendation
3M™ Scotch-Weld™ Urethane Adhesive, DP 605 NS	934.800	1 tube	1 tube per 4 roller carriers
3M™ Scotch-Weld™ EPX™ Plus II Applicator with 1:1 Plunger ²	934.801	1 applicator	1:1 plunger with 934.800 adhesive
3M™ Scotch-Weld™ EPX™ Plus II Mixing Square Nozzle, 5.3mm ³	934.805	Pk of 4	4 nozzles per 1 tube of adhesive
MUTO TLG gasket set	807.640	1 set	
Handling time frame	Function	Time	
	Working life (<i>time between application and clamping of carrier</i>)	5 minutes @ 75°F	
	Handling strength	20 minutes @ 73°F or more	
	Full cure time (<i>normal door usage not recommended until full cure time as been met</i>)	48 hours @ 73°F or more	

NOTE: Door glass should not be installed until the full cure time as been reached (see chart above).

Important safety-related information for the mounting and use of dormakaba glass hardware.

1.1 Clean clamping area with alcohol-based standard commercial cleaning agent before mounting the glass hardware.

1.2 Never clamp metal glass fitting hardware directly to glass surface.

1.3 Never use clamping product on surfaces with self-cleaning coatings.

2 Installation instructions

2.1 Overall

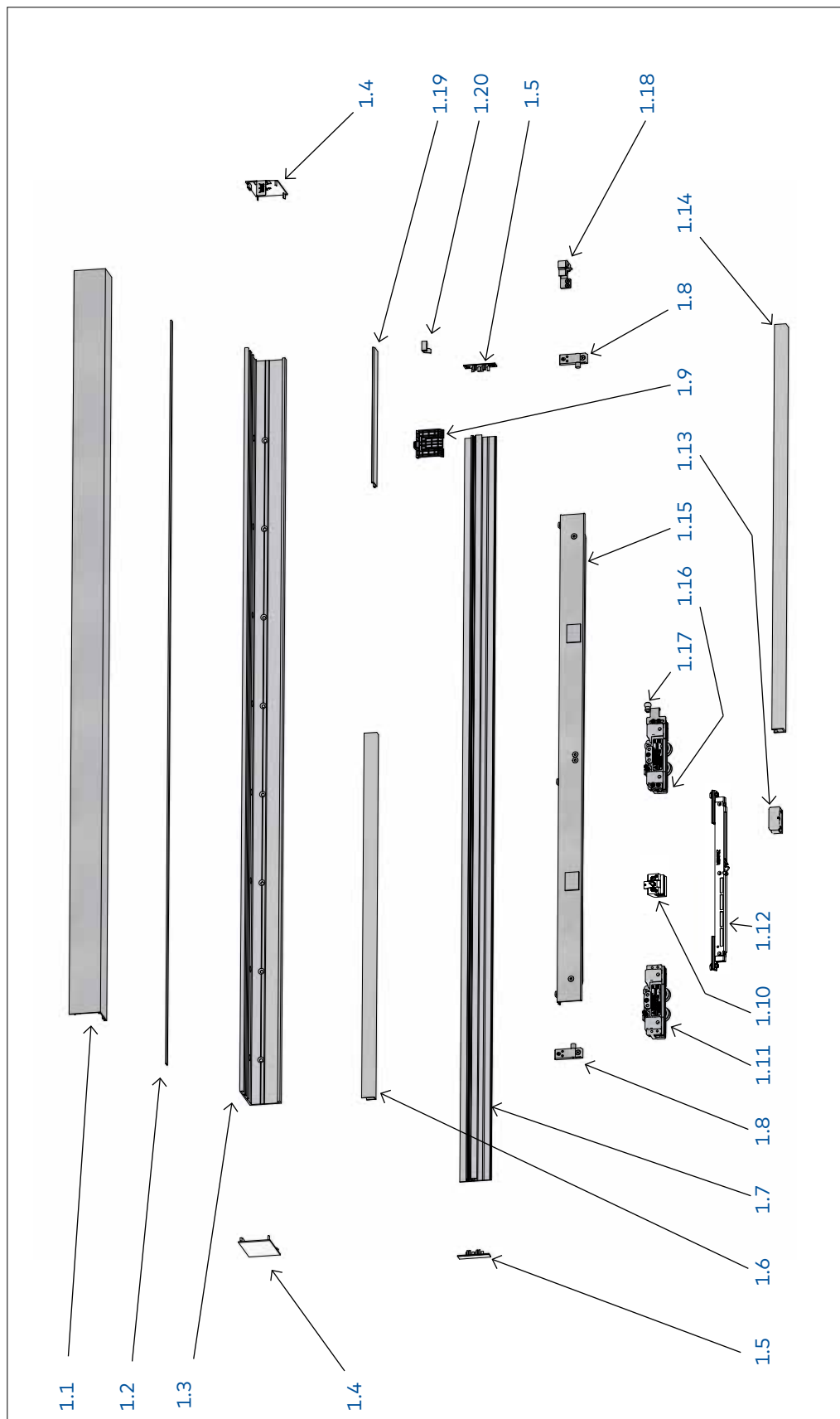

- | | | | | | |
|-----|--------------------------|------|----------------------------|------|----------------------------|
| 1.1 | Cover panel | 1.11 | Roller carrier | 1.17 | Self-close hold open ball |
| 1.2 | Brush strip | 1.12 | Dormotion unit | 1.18 | Self-close hold open clamp |
| 1.3 | Track | 1.13 | Floor guide | 1.19 | View protection profile |
| 1.4 | Cover end cap | 1.14 | U-channel | 1.20 | View protection clip |
| 1.5 | Sidelite profile end cap | 1.15 | Self-close cable unit | | |
| | | 1.16 | Self-close cable connector | | |
| | | 1.17 | | | |
| | | 1.18 | | | |
| | | 1.19 | | | |
| | | 1.20 | | | |

2.2 Door/wall dimensions

Single sidelite mount

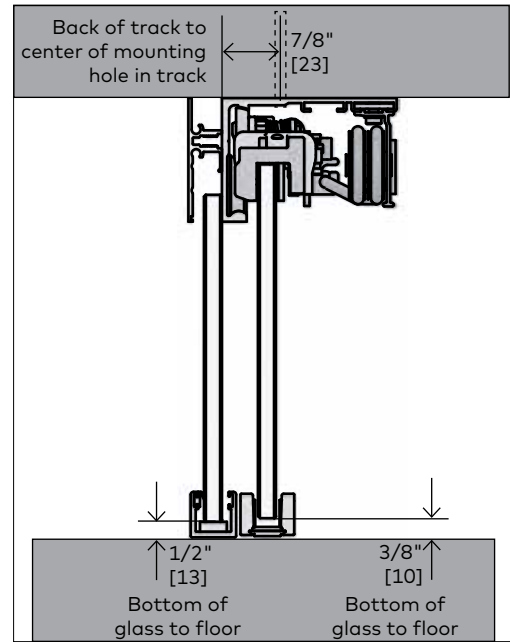
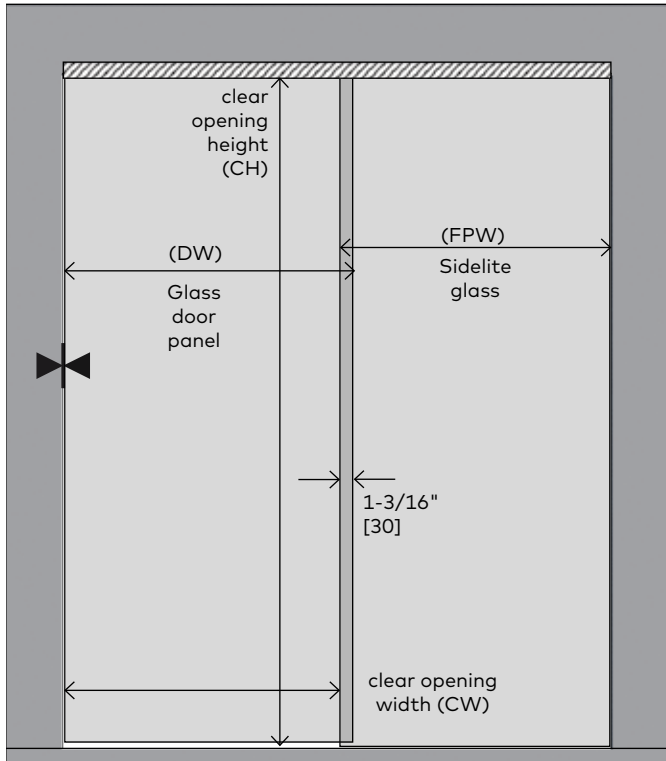

Multiple sidelite mount

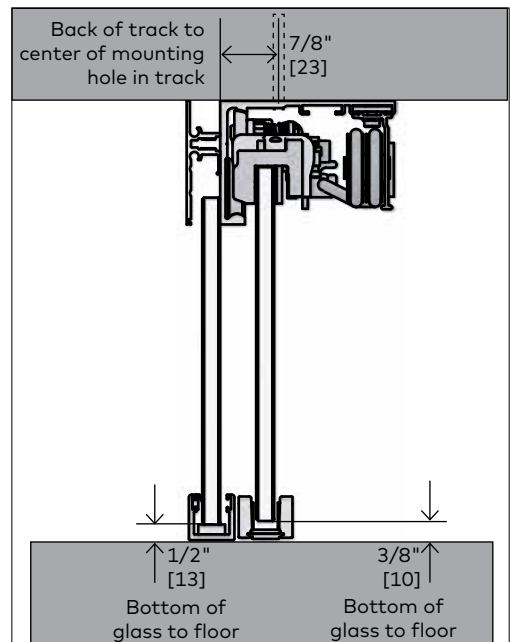
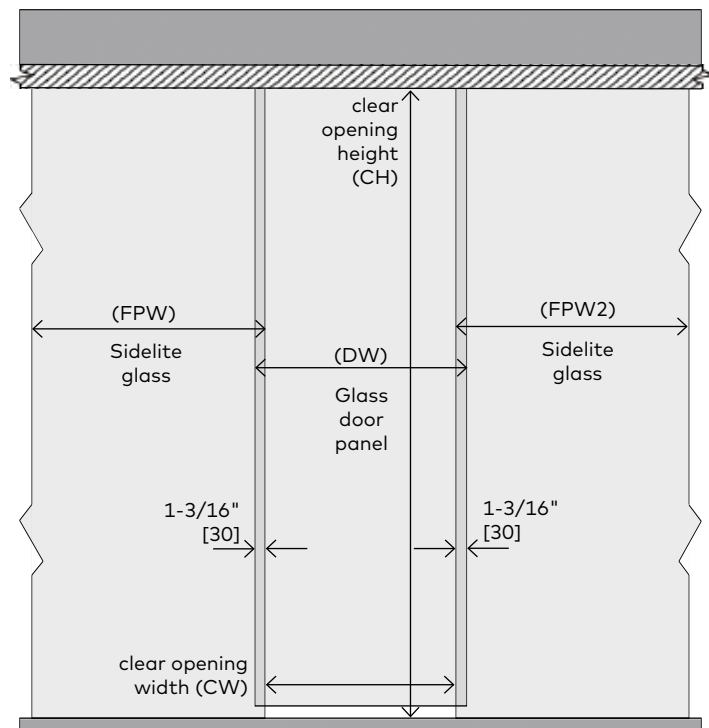

NOTE:

Overhead Reinforcement:

The overhead reinforcement must be a minimum of ¼" [6] x 3" [76] steel angle, 16 gauge metal stud, or two pieces of 1-1/2" [38] thick wood blocking [double stacked], secured to studs or joists on a maximum 16" [406] centers for the length of the track. The overhead reinforcement may be flush on the overhead surface or on the interior of this surface.

Track mounting screws must fully penetrate the steel angle, metal stud, or at a minimum of 2" [51] into wood blocking, utilizing the predrilled holes in the MUTO track.

Consult with a structural engineer to determine if reinforcement is adequate for your specific application or to meet specific codes in your location.

2.3 Installing the end stops

Fig. 1

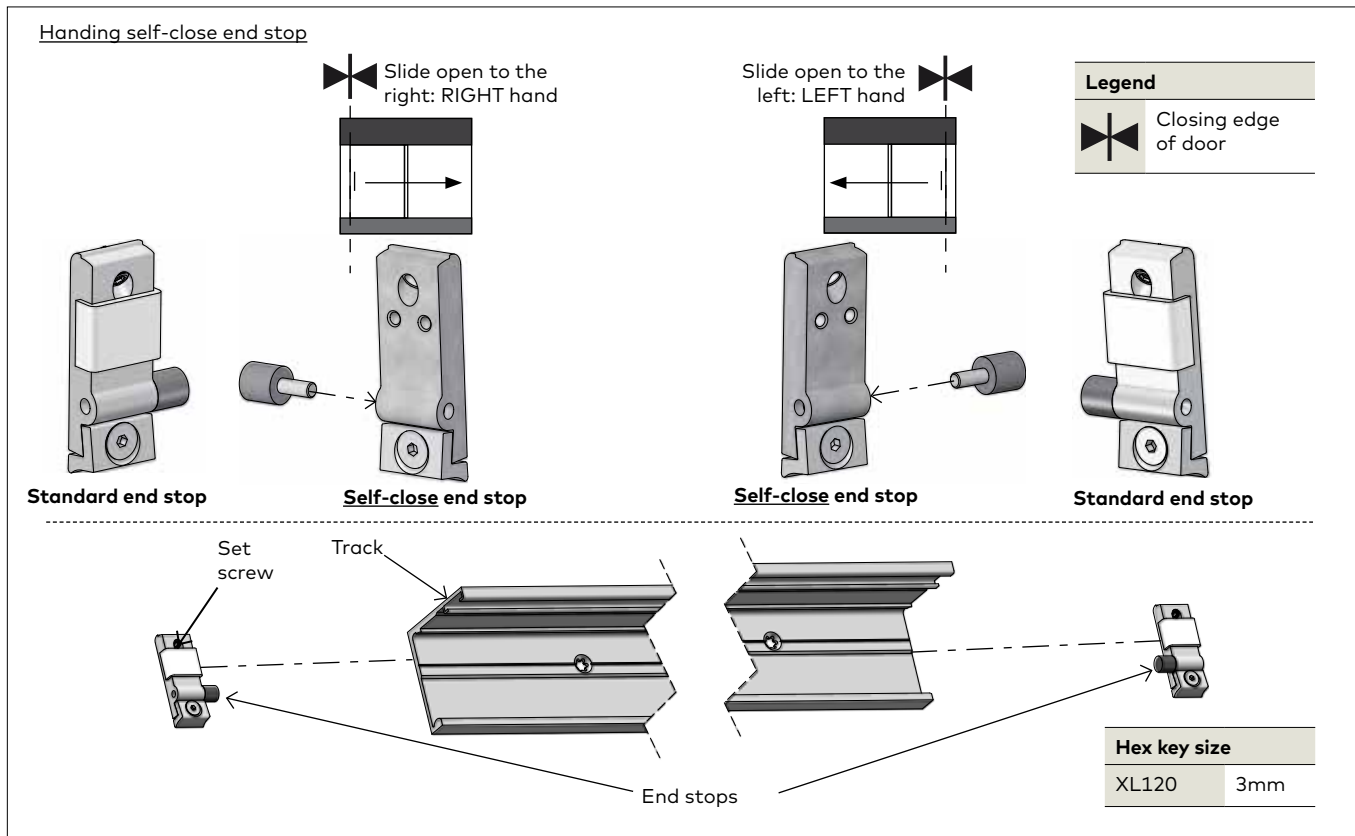

Handing the [closing side] end stop:

2.3.1 Determine closing edge of door.

• **SELF-CLOSE END STOP WILL BE USED ON CLOSING SIDE OF DOOR.**

2.3.2 Hand self-close end stop by inserting bumper on appropriate side of end stop.

Install both end stops:

2.3.3 Closing side of track: self-close end stop

2.3.4 Opening side of track: standard end stop

NOTE: Loosen bottom section of end stop for easier install.

NOTE: Be sure set screw is flush with back of bumper.

NOTE: Exact location/adjustments will be determined in the "Adjust End Stop Location" step.

2.4 Securing track to mounting surface

Fig. 2

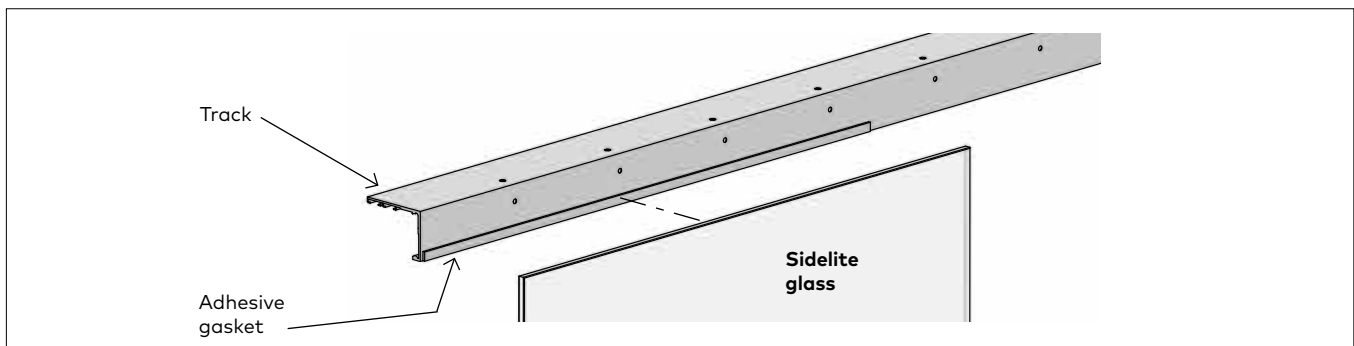

2.4.1 Ensure the track is cut to proper length.

NOTE: SEE DIMENSION INSTRUCTIONS ON PAGE 6.

2.4.2 Cut adhesive gasket equal to sidelite glass width.

2.4.3 Adhere gasket along bottom edge of back of track.

2.5 Securing sidelite section profile to track

Fig. 3

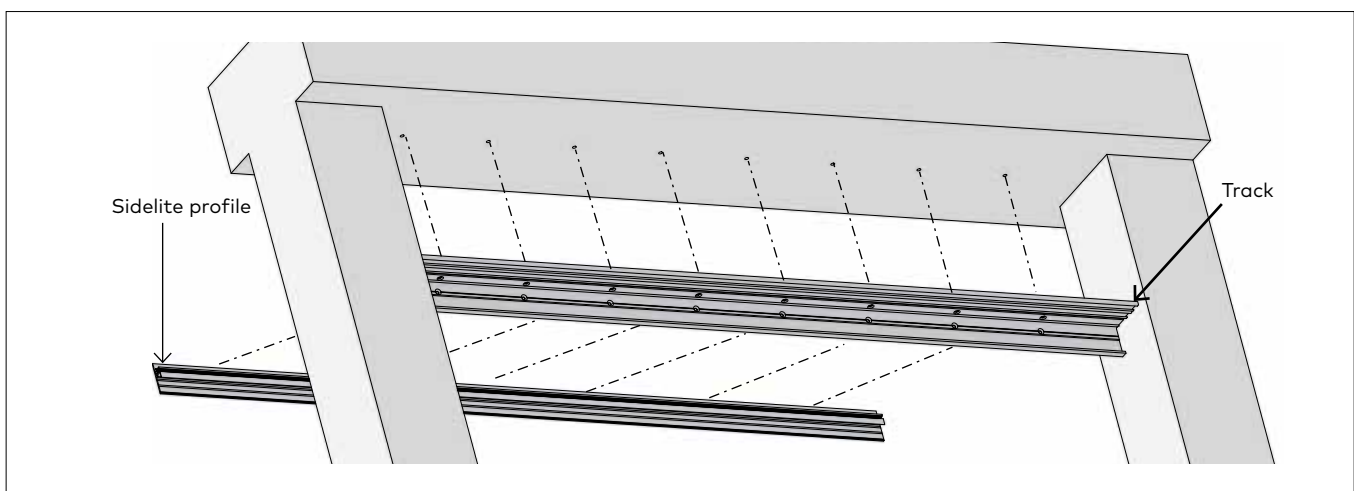

2.5.1 Secure track to mounting surface.

2.5.2 Align sidelite profile holes with track profile holes.

NOTE: Holes will be predrilled every 7-7/8" [200mm].

2.5.3 Secure with proper fasteners.

NOTE: Be sure fasteners are flush with track to avoid rollers catching protruding fasteners.

2.6 Installing U-channel for sidelite

Fig. 4

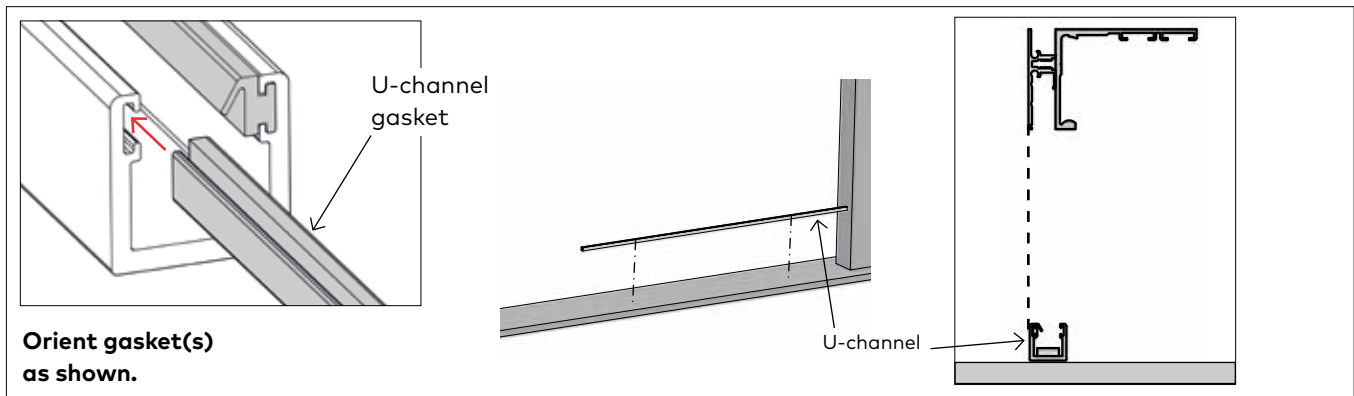

2.6.1 Secure u-channel to floor using appropriate fasteners.

NOTE: Ensure u-channel is plumb and the back of the u-channel profile aligns with back of sidelite profile.

NOTE: Gaskets are pre-installed.

2.7 Installing sidelite glass

Fig. 5

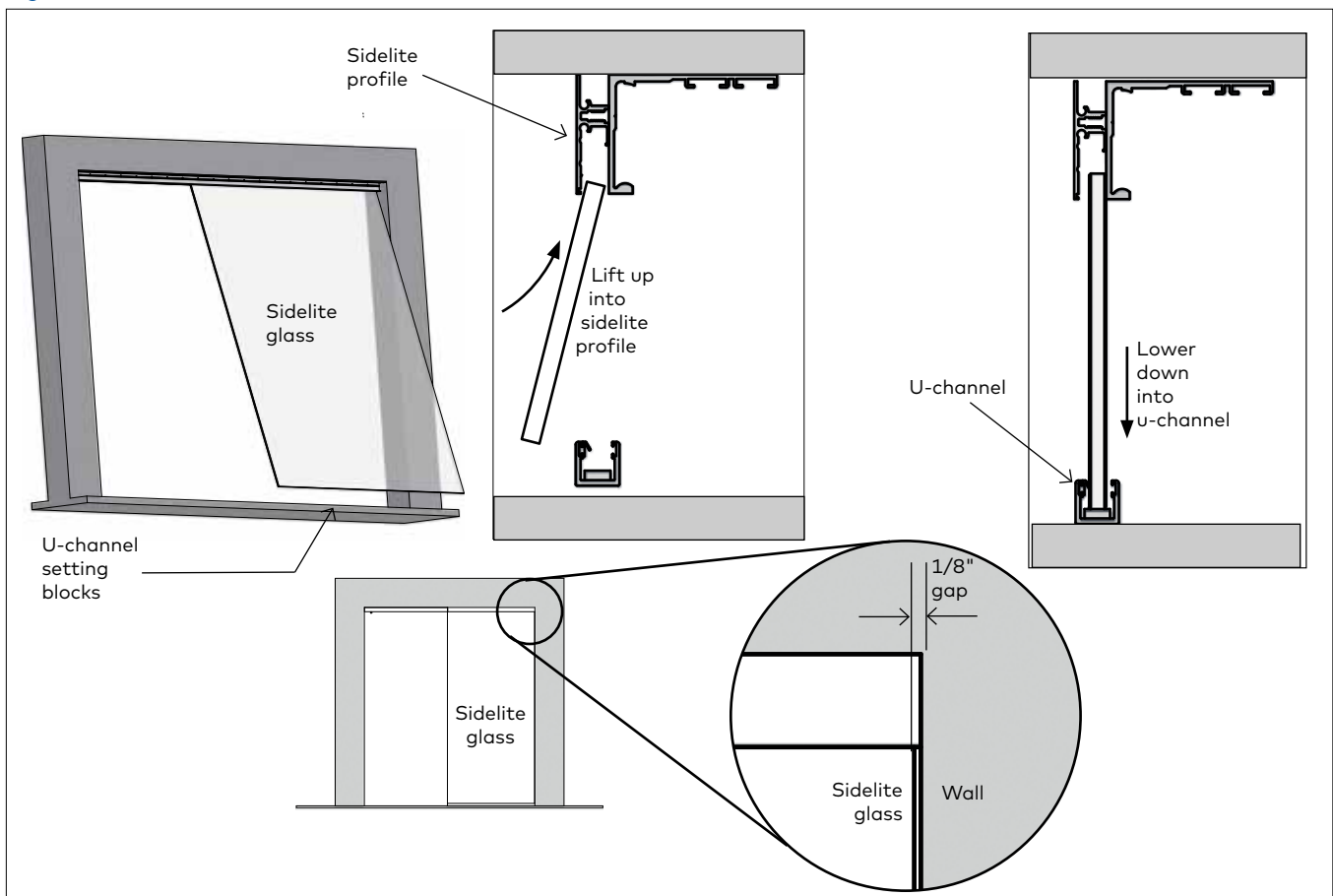

- 2.7.1 Place setting blocks into u-channel.
- 2.7.2 Spray inside of u-channel with glass cleaner.
- 2.7.3 Lift glass up and into sidelite profile.

- 2.7.4 Lower glass into u-channel.
- 2.7.5 Ensure there is 1/8" [3mm] gap between wall and edge of sidelite glass.
- 2.7.6 **If using tempered laminated glass, gently press glass panel against u-channel gasket and dispense silicone along full length of non-gasket side of u-channel.**

2.8 Install sidelite glass filler panel

Fig. 6

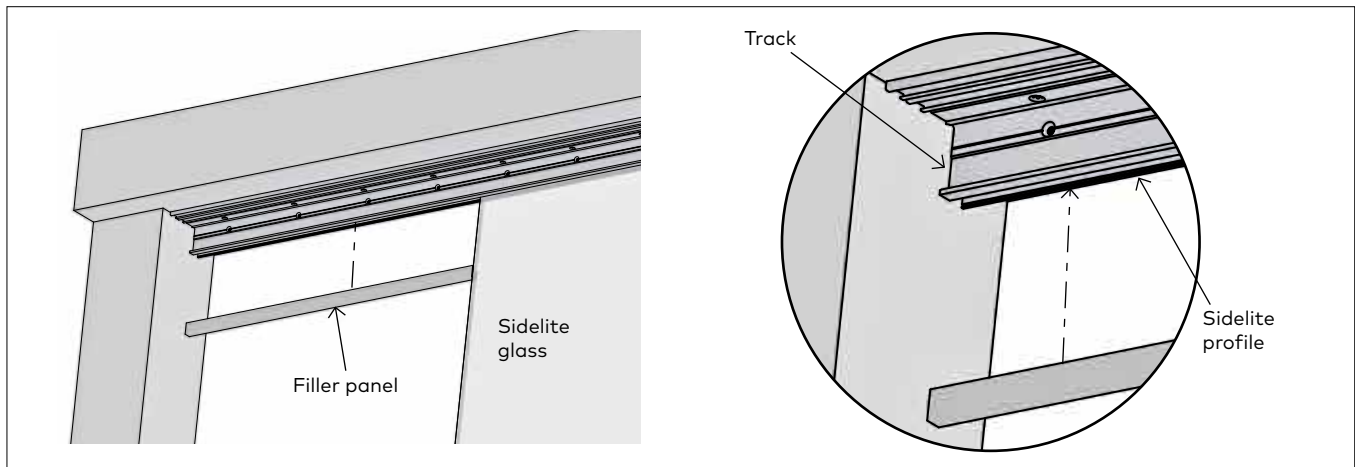

2.8.1 Fit filler panel between track and sidelite profile, on door side.

2.9 Install sidelite glass gasket

Fig. 7

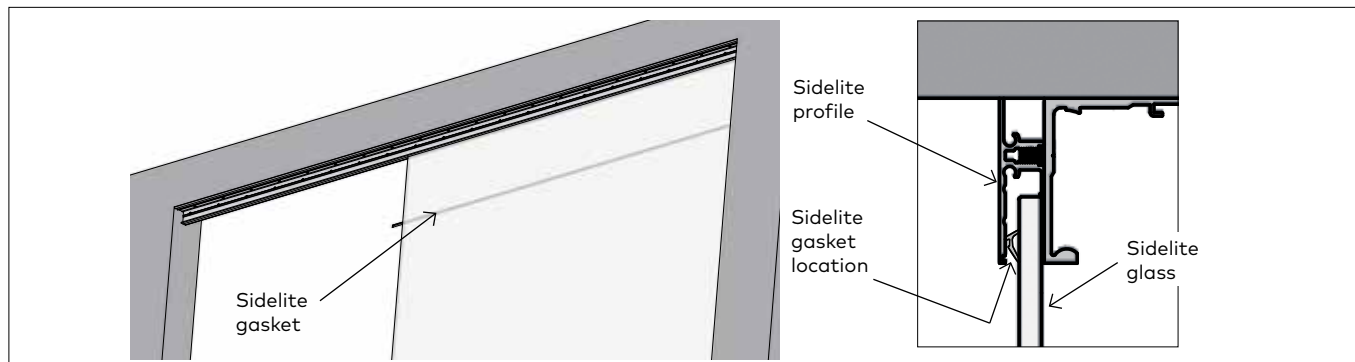

2.9.1 Cut gasket to length per chart above.

2.9.2 Press gasket in between sidelite glass and sidelite profile.

2.10 Disengaging the anti-jump

Fig. 8

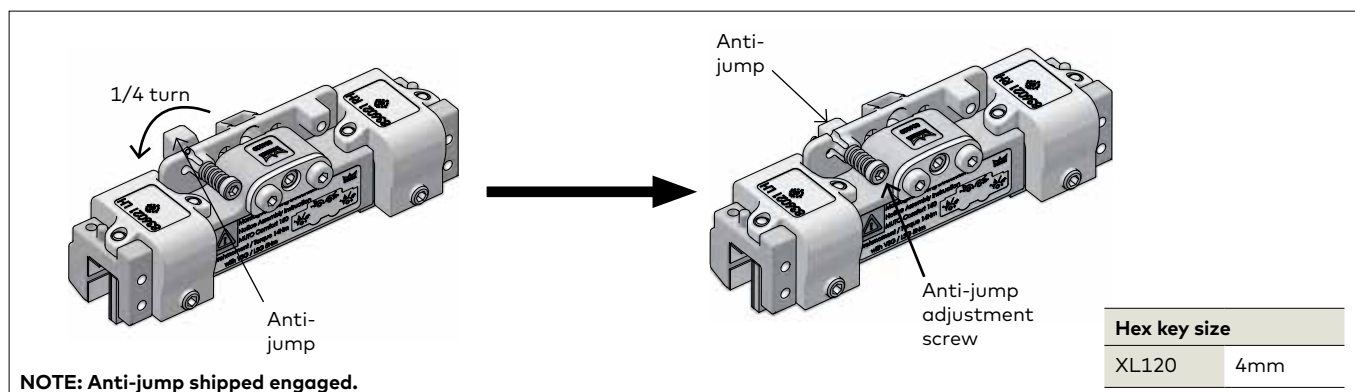

NOTE: Anti-jump shipped engaged.

2.10.1 Disengage the anti-jump on roller carrier.

2.10.2 Using a appropriate-size hex key, push anti-jump adjustment screw IN and turn **COUNTER-CLOCKWISE** to **disengage** anti-jump.

2.11A Installing roller carriers: on monolithic glass ONLY

Fig. 9

⚠ DETERMINE THE LEADING (X) VERSUS TRAILING (Z) EDGE OF THE GLASS.
"LEADING IS SIDE CLOSEST TO LATCH CLOSED."

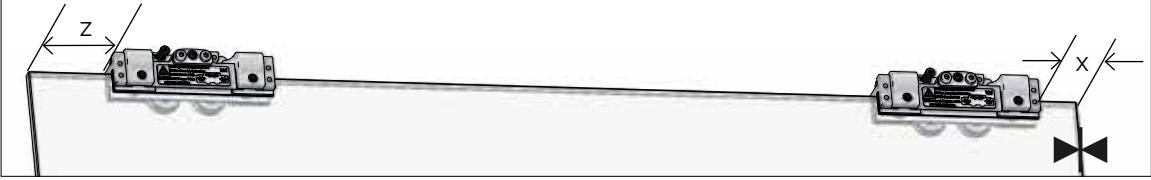

Roller location on glass with DORMOTION unit		
		XL120
Single door	X	2-3/8" [60]
Single door	Z	3-1/8" [80]
Double door	X	2-3/8" [60]
Double door	Z	3-1/8" [80]

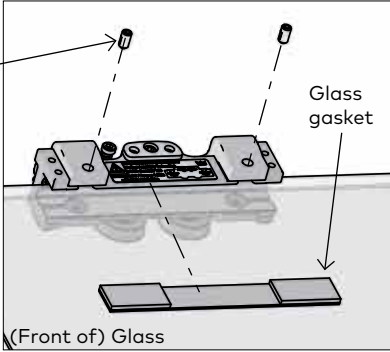

Secure

Glass gasket

(Front of) Glass

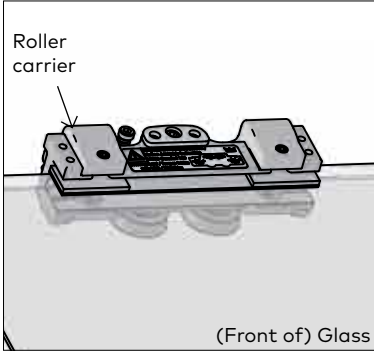

Roller carrier

(Front of) Glass

Legend

Closing edge of door

Hex key size	
XL120	4mm

Torque value:	
XL120	10.3ft lbs [14Nm]

⚠ NOTE: FULLY CLEAN SURFACE OF GLASS WITH AN ALCOHOL-BASED MILD GLASS AND SURFACE CLEANER. ENSURE NO DEBRIS IS ON THE GASKET.

⚠ NOTE: ENSURE ROLLER CARRIER WHEELS ARE FREE OF DEBRIS.

2.11A.1 Slide roller carriers onto glass.

2.11A.2 Slide glass gasket and metal shim between glass and roller carrier.

- NOTE: Orient gasket with rubber side facing the glass.**

2.11A.3 Secure roller carriers to glass using appropriate-size hex key at 10.3 ft lbs (14 Nm).

2.11B Installing roller carriers: on tempered laminate glass ONLY

Fig. 10

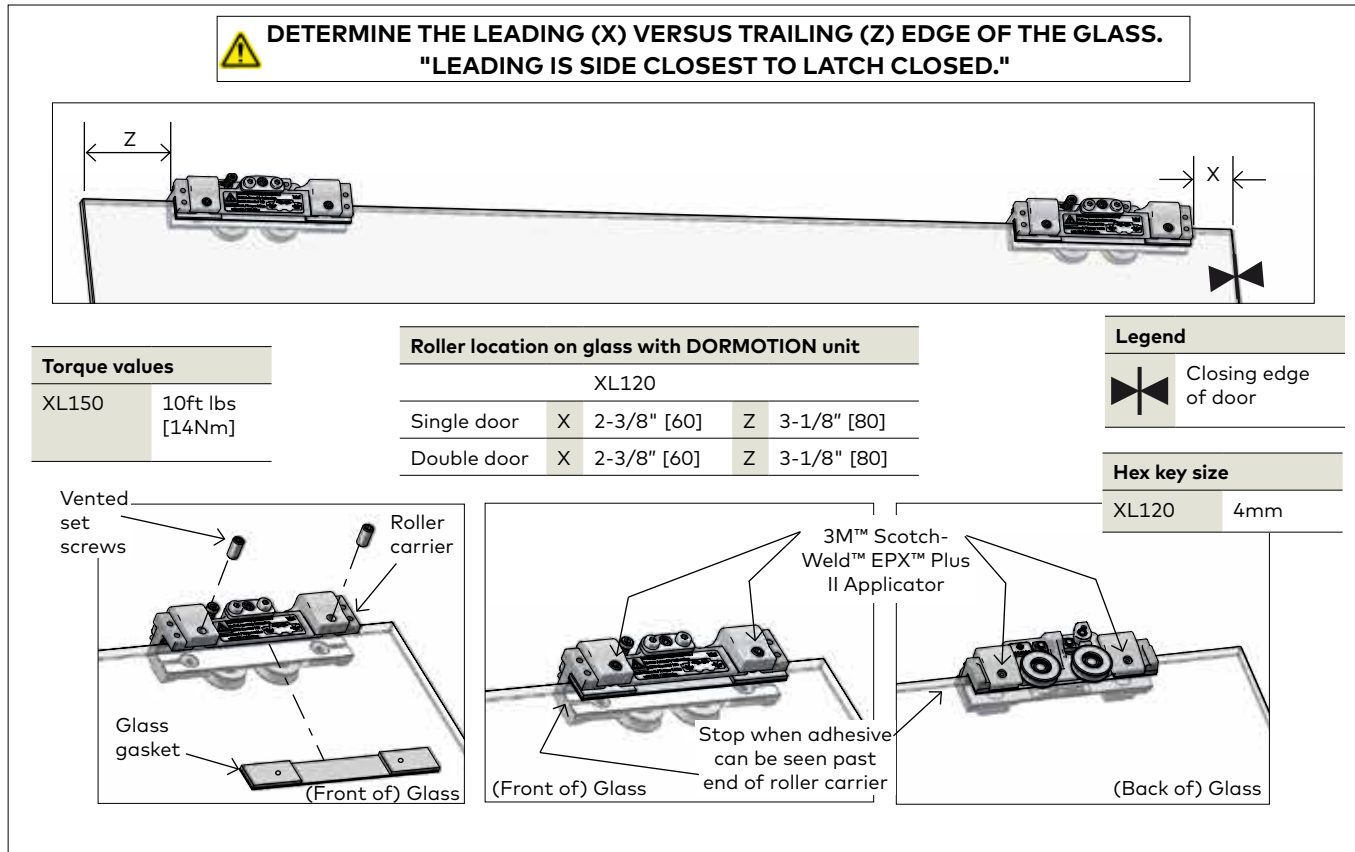

⚠ NOTE: THE RECOMMENDED ADHESIVE'S SET-UP TIME IS 20 MINUTES FOR THE DUO-PAK CARTRIDGES.

⚠ NOTE: USE 1:1 RATIO PLUNGER WITH THE 3M™ Scotch-Weld™ Urethane Adhesive.

⚠ NOTE: FULLY CLEAN SURFACE OF GLASS WITH AN ALCOHOL-BASED MILD GLASS AND SURFACE CLEANER. ENSURE NO DEBRIS IS ON THE GASKET.

⚠ NOTE: ENSURE ROLLER CARRIER WHEELS ARE FREE OF DEBRIS.

2.11B.1 Slide carriers onto glass.

2.11B.2 Replace existing gasket with TLG gasket.

2.11B.3 Slide laminated glass gasket and metal shim between glass and roller carrier.

NOTE: Orient gasket with rubber side facing the glass.

2.11B.4 Replace existing set screws with vented set screws.

2.11B.5 Tighten vented set screws at 4 ft-lbs (5Nm).

NOTE: Onto scrap material, first dispense approximately 12" of 3M™ Scotch-Weld™ Urethane Adhesive prior to application to prevent mixing errors and ensure optimal hardening.

2.11B.6 Dispense adhesive into vented set screws on both sides of carrier.

⚠ Stop application when adhesive can be seen past edge of roller carrier.

⚠ DO NOT WIPE any excess adhesive from glass surface. Allow adhesive to dry and scrape off glass surface with a beveled-edge chisel or putty knife.

NOTE: Keep glass flat during curing process.

NOTE: See chart in Specifications section for appropriate curing time.

2.12 Installing DORMOTION start/stop

Fig. 11

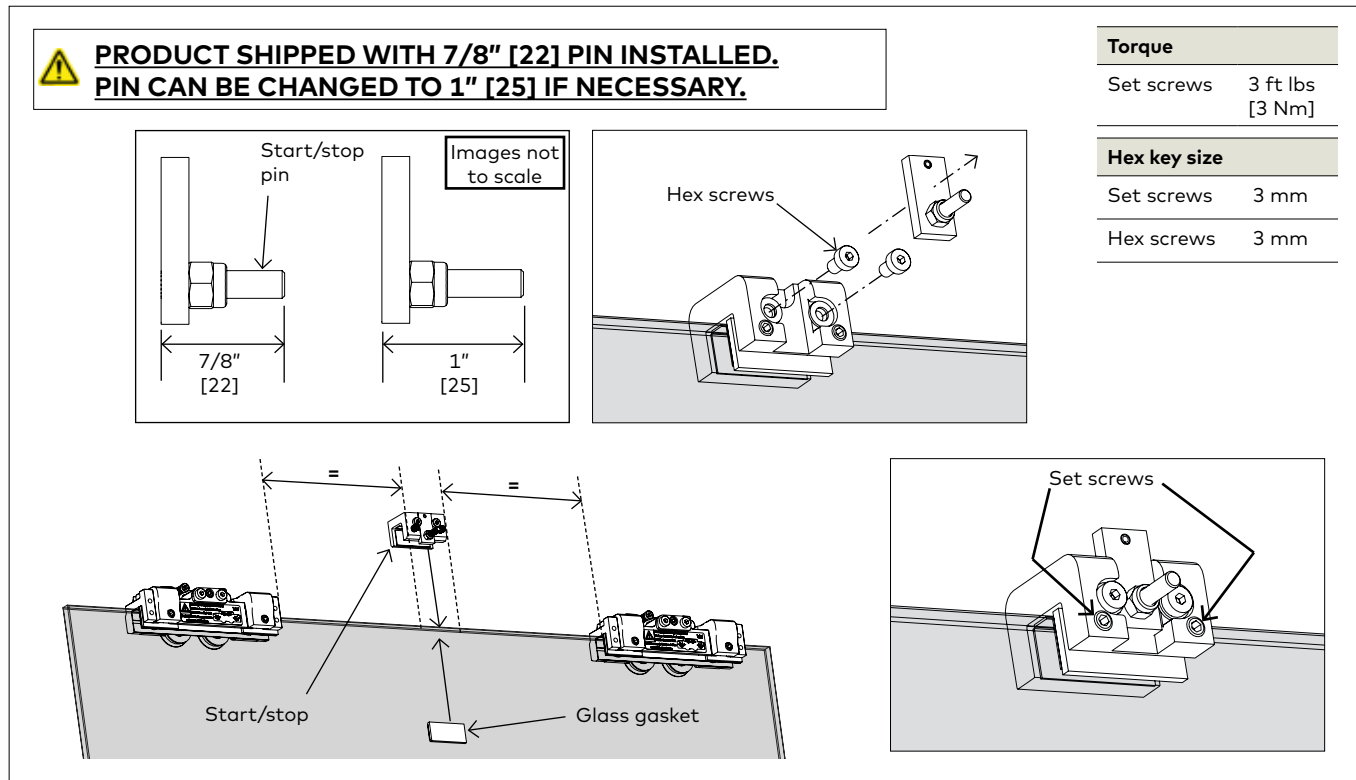

NOTE: Determine a pin length based upon how square and plumb the opening is.

2.12.1 If required, change pin in start/stop assembly.

- Remove hex screws.
- Remove existing pin and plate.
- Swap in appropriate pin and plate.
- Replace hex screws.

2.12.2 Slide start/stop onto glass.

2.12.3 Center equally between the carriers.

2.12.4 Slide glass gasket between start/stop and glass.

NOTE: Orient with gasket facing glass.

2.12.5 Secure start/stop via set screws.

2.13 Install glass/rollers on track

Fig. 12

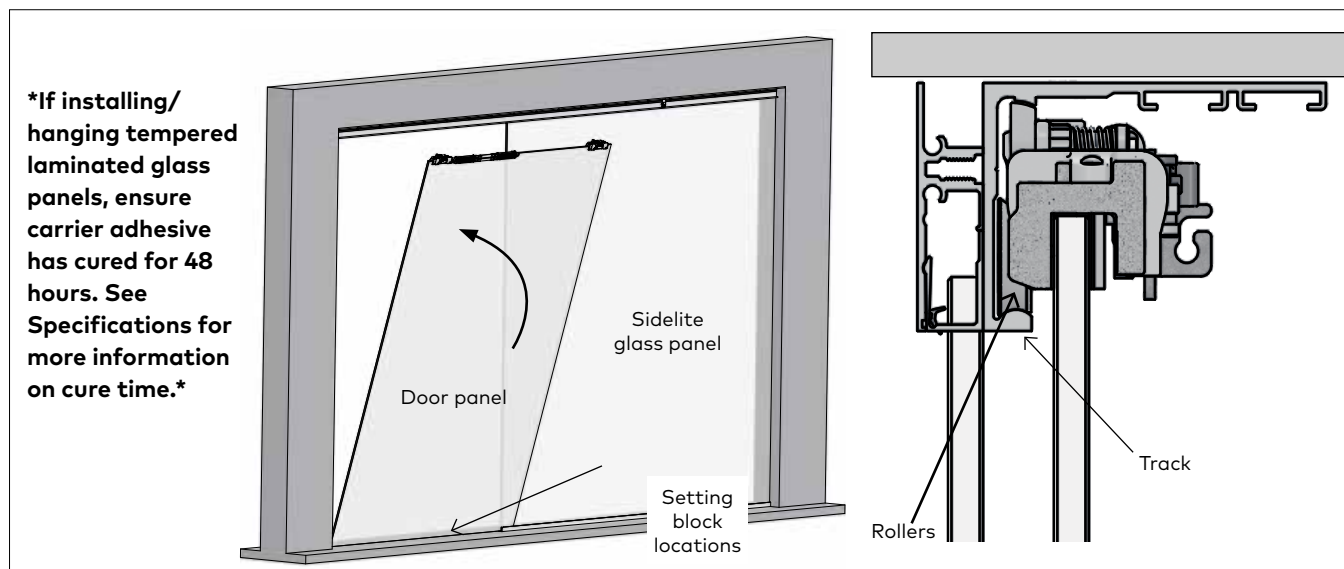

If installing/hanging tempered laminated glass panels, ensure carrier adhesive has cured for 48 hours. See Specifications for more information on cure time.

⚠ ENSURE ROLLERS AND TRACK ARE FREE OF DEBRIS.

2.13.1 Place glass on setting blocks on floor for stability.

2.13.2 Tip glass and rollers upward and rest rollers on track.

2.14 Install floor guide

Fig. 13

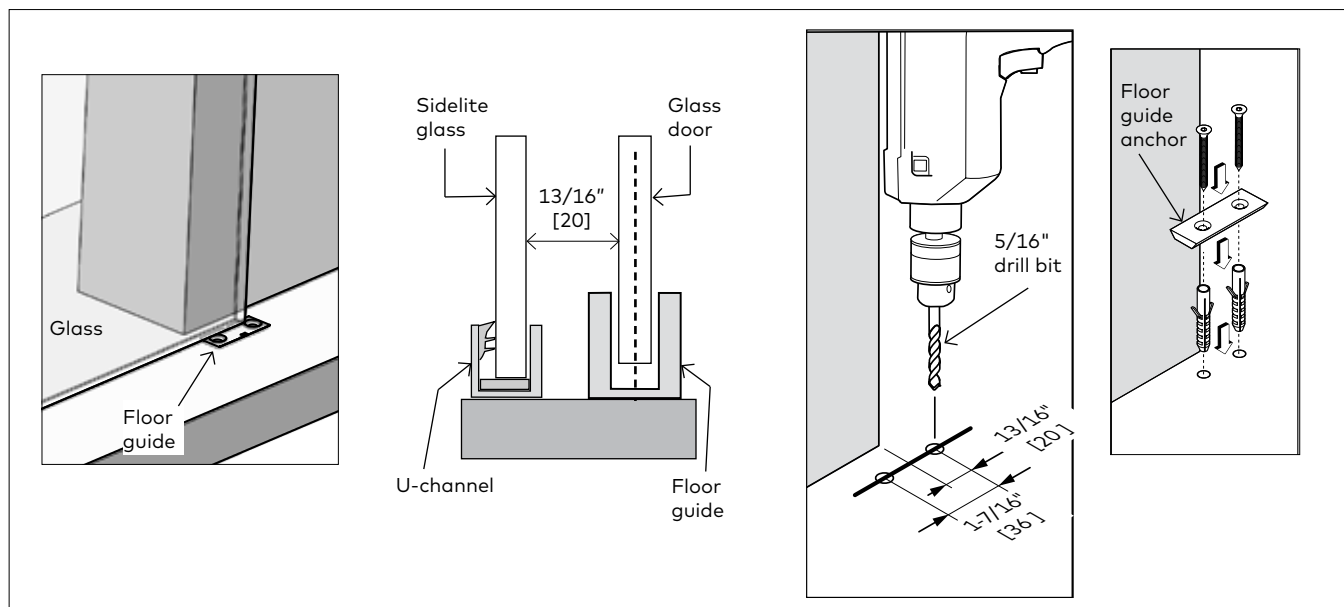

⚠ ANTI-JUMP IS DISENGAGED!

2.14.1 Align centerline of glass with centerline of floor guide.

2.14.2 Be sure the glass is plumb.

2.14.3 Mark appropriate floor guide measurements.

NOTE: Center of floor guide should be 13/16" [20] off the corner of the wall.

2.14.4 **TEMPORARILY REMOVE GLASS AND ROLLERS FROM TRACK.**

2.14.5 Pre-drill into mounting surface using a 5/16" drill bit.

2.14.6 Secure floor guide anchor with included fasteners.

2.15 Install floor guide: continued

Fig. 14

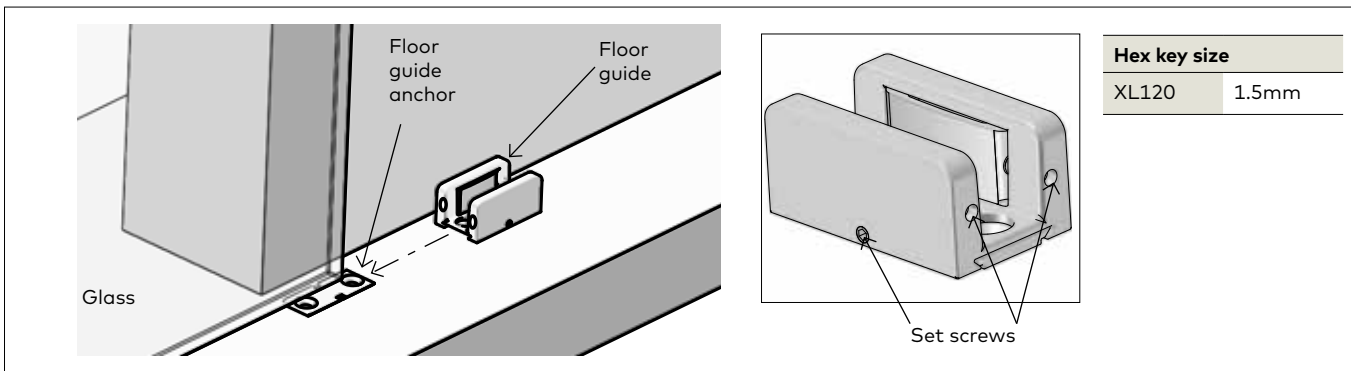

2.15.1 **SET GLASS AND ROLLERS BACK ONTO TRACK.**

2.15.2 Slide floor guide over floor guide anchor and tighten with set screws.

2.15.3 Remove setting blocks.

NOTE: Be sure glass is centered in floor guide.

2.16 Engaging the anti-jump

Fig. 15

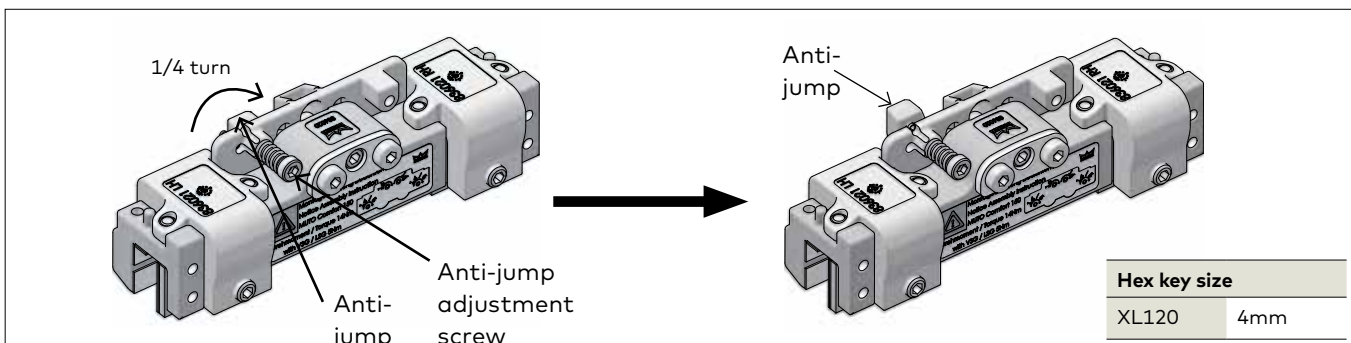

2.16.1 Engage the anti-jump on roller carrier.

2.16.2 Using the appropriate-size hex key, push anti-jump adjustment screw **IN** and turn **CLOCKWISE** to **engage** anti-jump.

2.17 Adjustment door height

Fig. 16

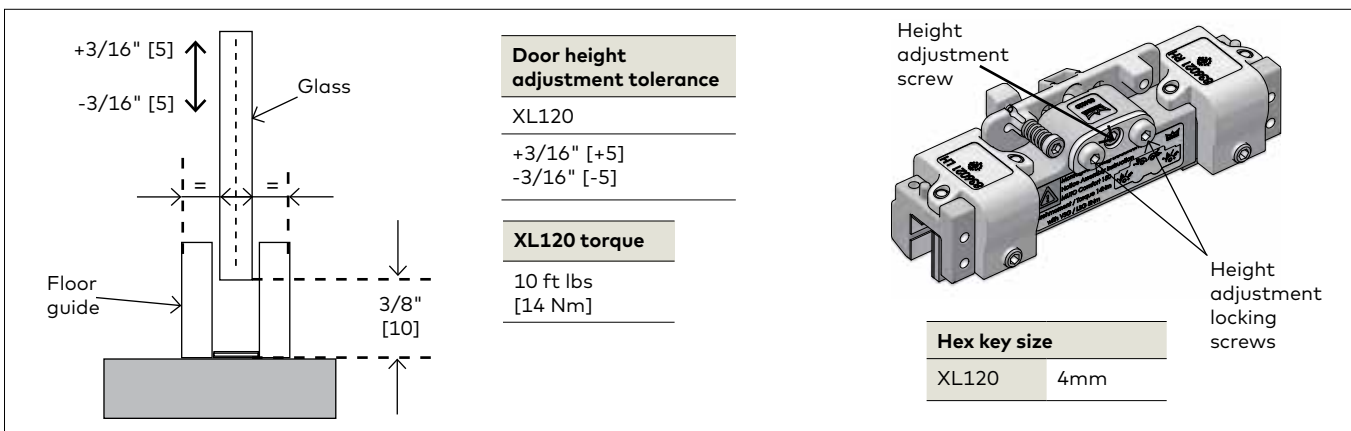

2.17.1 Set height of glass door.

2.17.2 Loosen height adjustment locking screws of carrier.

2.17.3 Using appropriate-size hex key, turn height adjustment screw **CLOCKWISE** or **COUNTER-CLOCKWISE** to raise or lower glass.

NOTE: Be sure glass is level during this adjustment.

2.18 Adjustment end stop location: LEADING end stop

Fig. 17

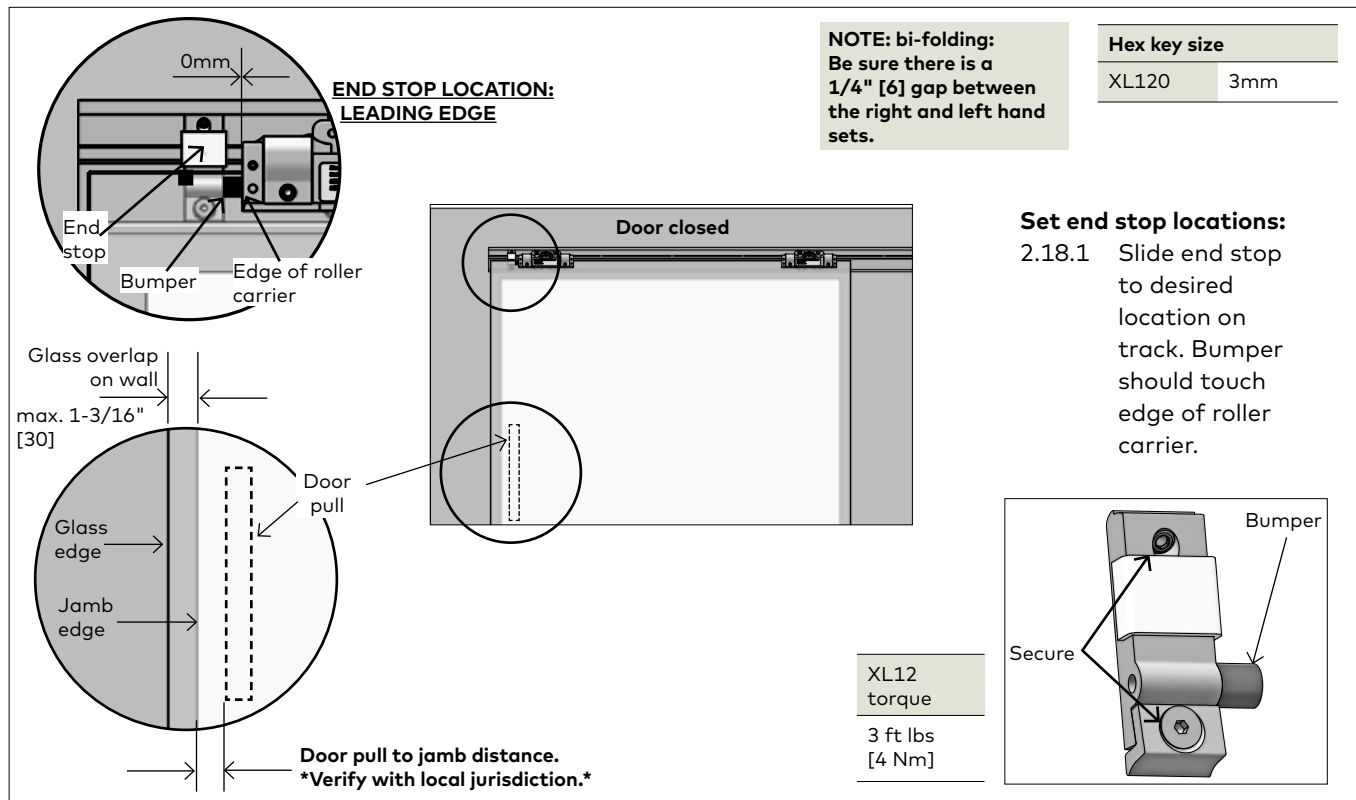

Adjustment end stop location: TRAILING end stop

Fig.18

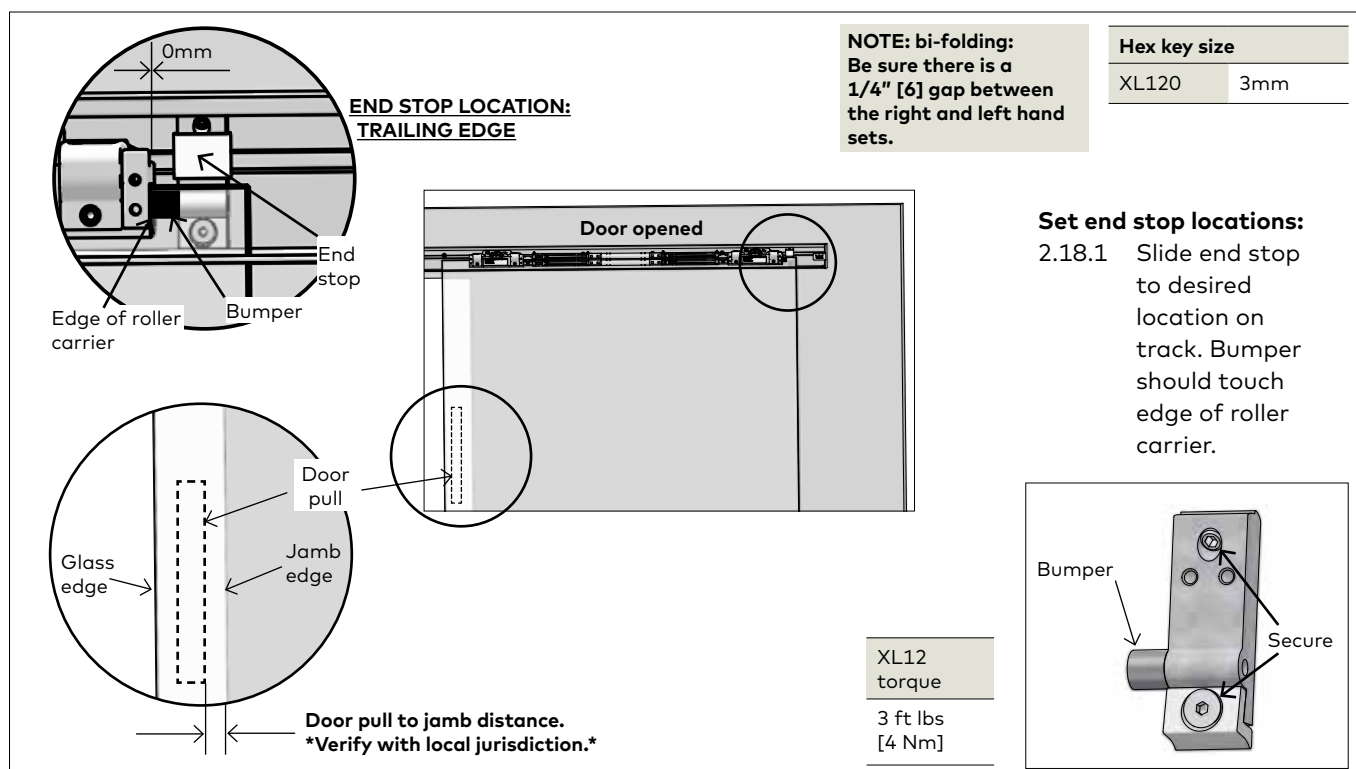

2.19 Install RH DORMOTION unit - door closed

Fig. 19

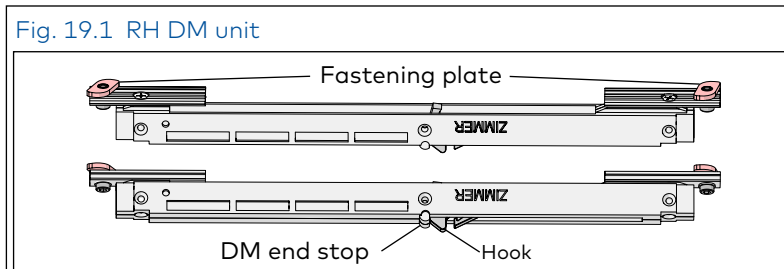

Fig. 19.2 RH DM unit fastening plates rotated

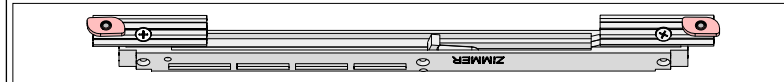

Fig. 19.3 RH DM unit inserted in track

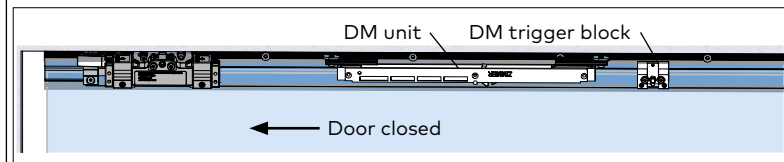

Fig. 19.4 DM unit hook positioned in trigger

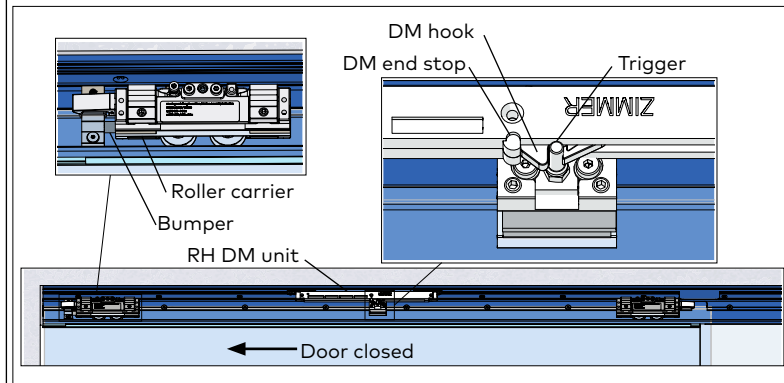

Fig. 19.5 DM unit end stop positioned 5 mm from DM hook

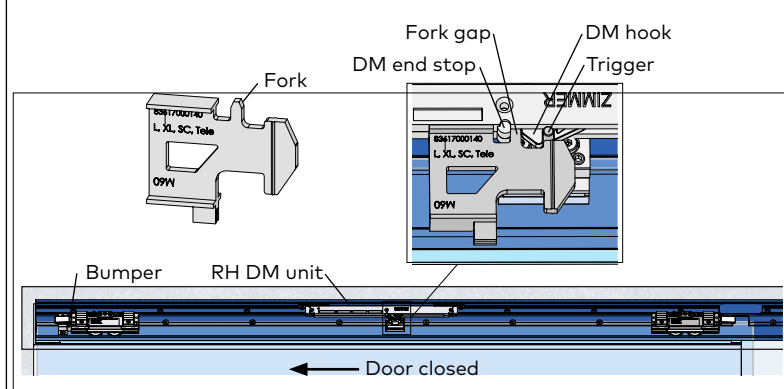
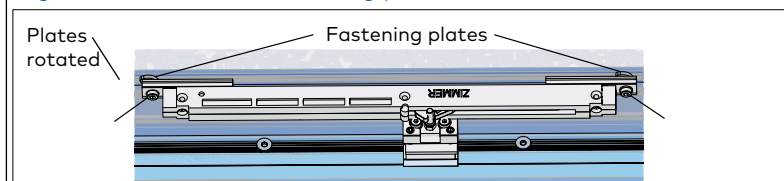

Fig. 19.6 RH DM unit fastening plates secured in track



2.19.1 Rotate RH DM fastening plates.

- Using 4 mm hex key, loosen fastening plate hex screws.
- Rotate fastening plates until they are parallel to the DM unit (Fig. 19.2)
- Snug hex screws.

2.19.2 Move door to close position.

- For installation of RH DM unit, door must be in the closed position against bumper.

Fig. 19.7 RH DM unit aligned in track

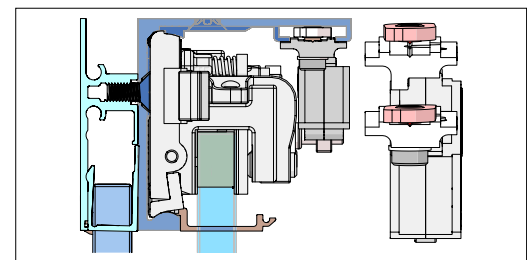

2.19.3 Align DM unit in track, engage DM hook in DM trigger.

- Align DM unit in track (Fig. 19.7).
- Slide DM unit over the DM trigger block until the DM hook engages the DM trigger (Fig. 19.4)

2.19.4 Set DM unit final position.

- NOTE: Insure door is fully closed against bumper before performing this step.
- While the door is being held closed, slide DM unit over until there is a 5 mm gap between the DM hook and the DM end stop (Fig. 19.5).

2.19.5 Secure the DM unit in position.

- NOTE: Insure door is fully closed against bumper before performing this step.
- Using 4 mm hex key, tighten DM unit fastening plate socket head cap screws. Fastening plates must engage the track (Fig. 19.6 and .8).

Torque

Socket head cap screws	3 ft lbs [3 Nm]
------------------------	--------------------

Fig. 19.8 RH DM unit installed in track

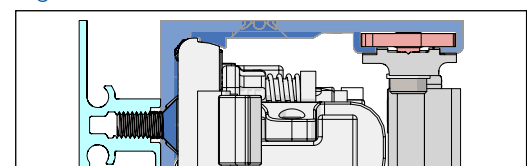

2.20 Install LH DORMOTION unit - door open

Fig. 20 LH DM unit installation

Fig. 20.1 LH DM unit

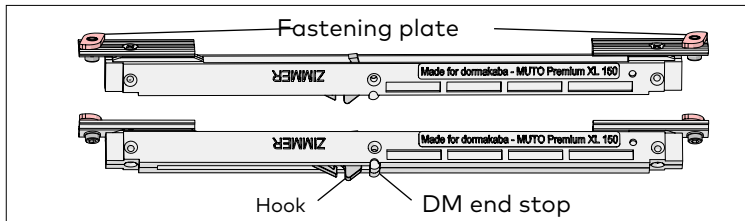

Fig. 20.2 LH DM unit fastening plates rotated

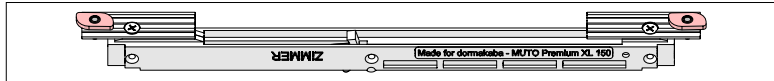

Fig. 20.3 LH DM unit inserted in track

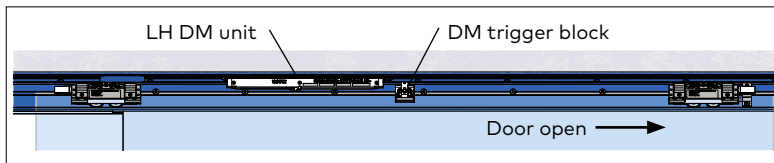

Fig. 20.4 DM unit hook positioned in trigger

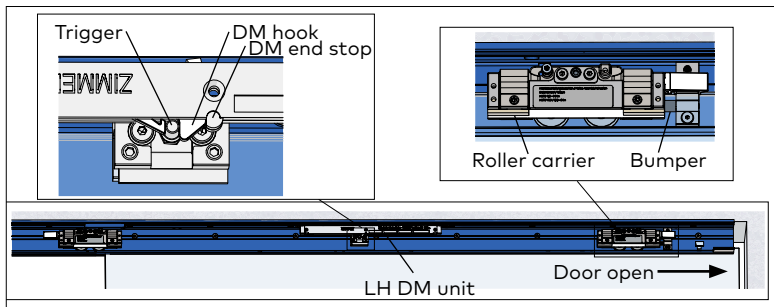

Fig. 20.5 DM unit end stop and hook separation adjustment

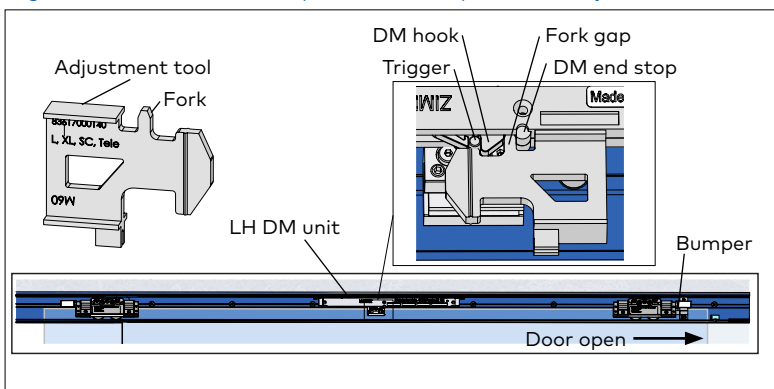
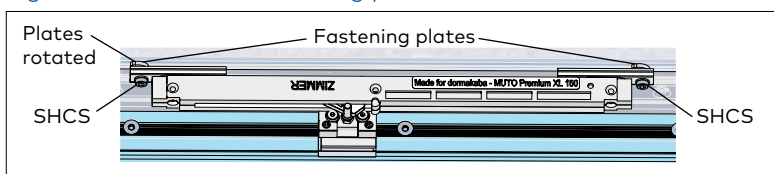

Fig. 20.6 LH DM unit fastening plates secured in track



2.20.1 Rotate DM fastening plates.

- Using 4 mm hex key, loosen fastening plate hex screws.
- Rotate fastening plates until they are parallel to the DM unit (Fig. 20.2)
- Snug hex screws.

2.20.2 Move door to open position.

- For installation of LH DM unit, door must be in the open position against bumper.

Fig. 20.7 LH DM unit aligned in track

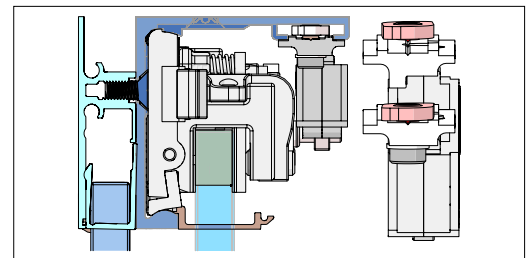

2.20.3 Align DM unit in track, engage DM hook in DM trigger.

- Align DM unit in track (Fig. 20.7).
- Slide DM unit over the DM trigger block until the DM hook engages the DM trigger (Fig. 20.4)

2.20.4 Set DM unit final position.

- Place adjustment tool flat against DM unit with fork between DM hook and DM end stop (Fig. 20.5).
- Slide DM unit over until hook and DM end stop are against the fork. This sets 5 mm gap (fork gap).
- **Trigger height:** Adjust so trigger sets on top of adjustment tool (Para. 2.21).

2.20.5 Secure the DM unit in position.

- NOTE: Insure door is fully open against bumper before performing this step.
- Using 4 mm hex key, tighten DM unit fastening plate socket head cap screws . Fastening plates must engage the track (Fig. 20.8).

Torque

Socket head cap screws 3 ft lbs [4 Nm]

Fig. 20.8 LH DM unit installed in track

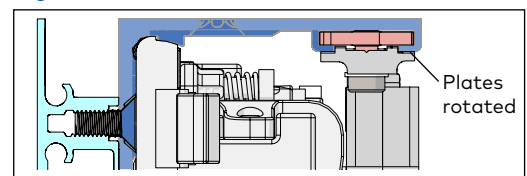

2.21 Adjust start/stop pin height (if necessary)

Fig. 21

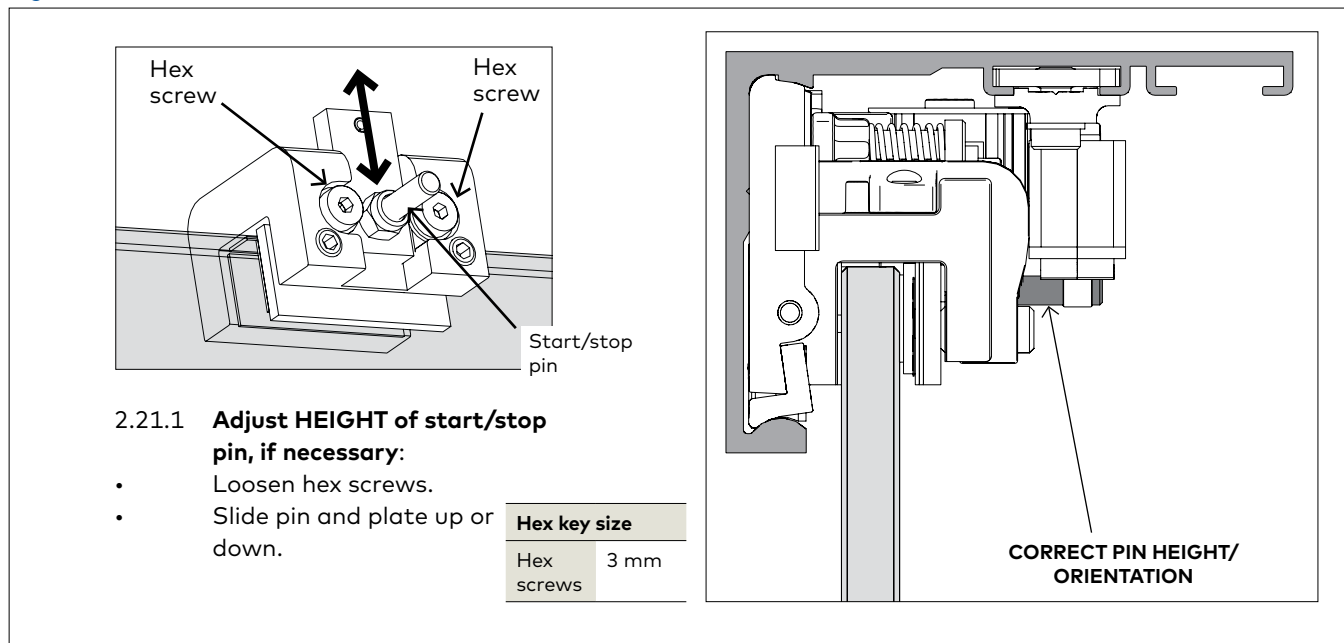

2.22 Self-close unit: Install self-close hold open clamp

Fig. 22

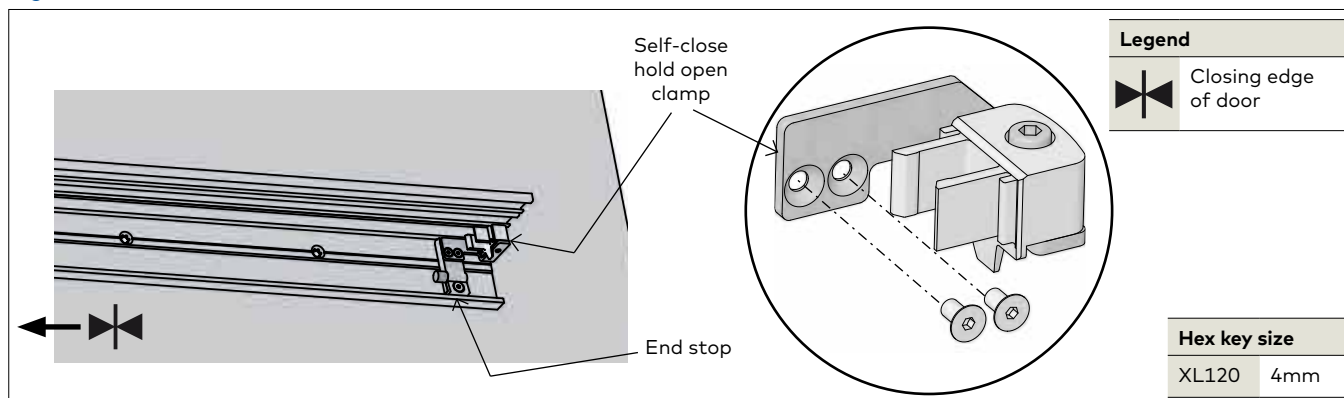

2.22.1 Secure self-close hold open clamp to the end stop furthest from latch [closing side].

- Use two screws and tighten to 2.5 ft lbs (3Nm).

2.23 Self-close unit: Install self-close hold open ball

Fig. 23

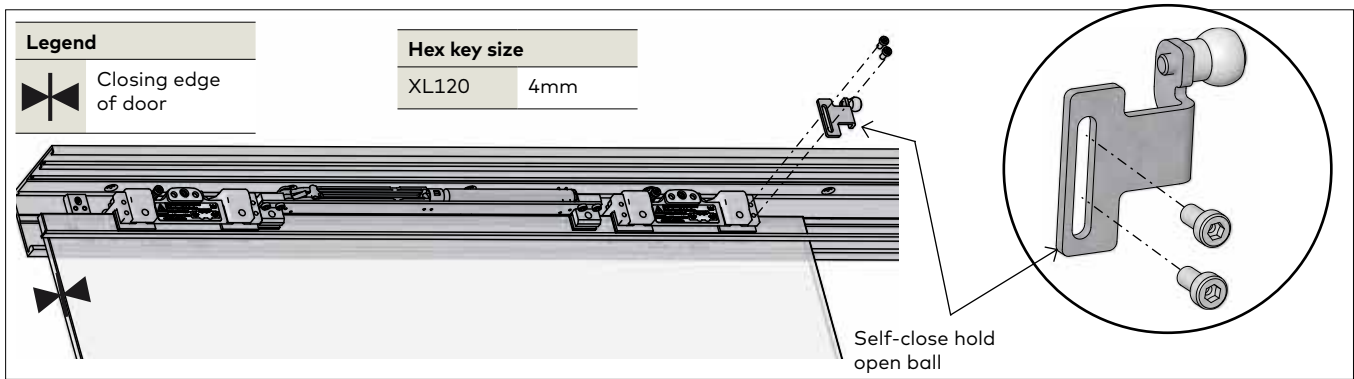

2.23.1 Secure self-close hold open ball to carrier furthest from latch [closing side].

• Use two screws and tighten at 2.5 ft lbs [3Nm].

2.24 Self-close unit: Install self-close cable connector

Fig. 24

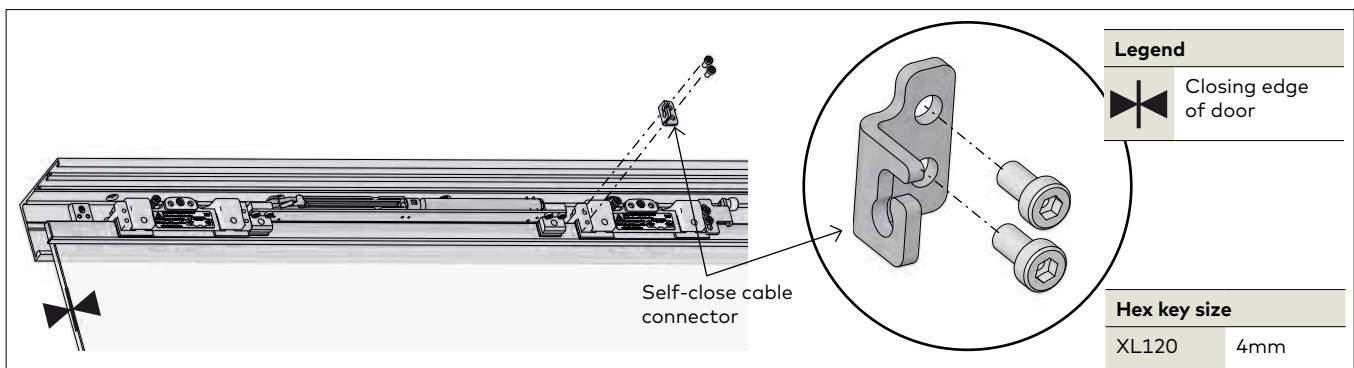

2.24.1 Secure self-close cable connector to opposite end of carrier, furthest from latch [closing side].

• Use two screws and tighten at 2.5 ft lbs [3Nm].

2.25 Self-close unit: Install self-close cable unit

Fig. 25

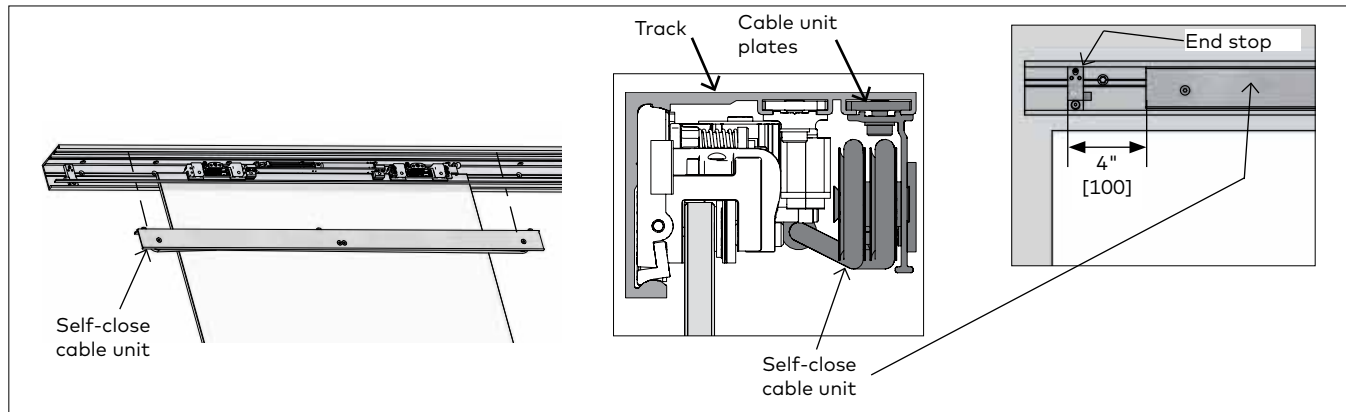

- 2.25.1 Secure self-close cable unit into first groove of MUTO track.
 - 2.25.2 Rotate plates inside track channel to engage.
- Use three screws/plates and tighten at 3 ft lbs [4 Nm].

2.26 Self-close unit: Prepare self-close cable unit

Fig. 26

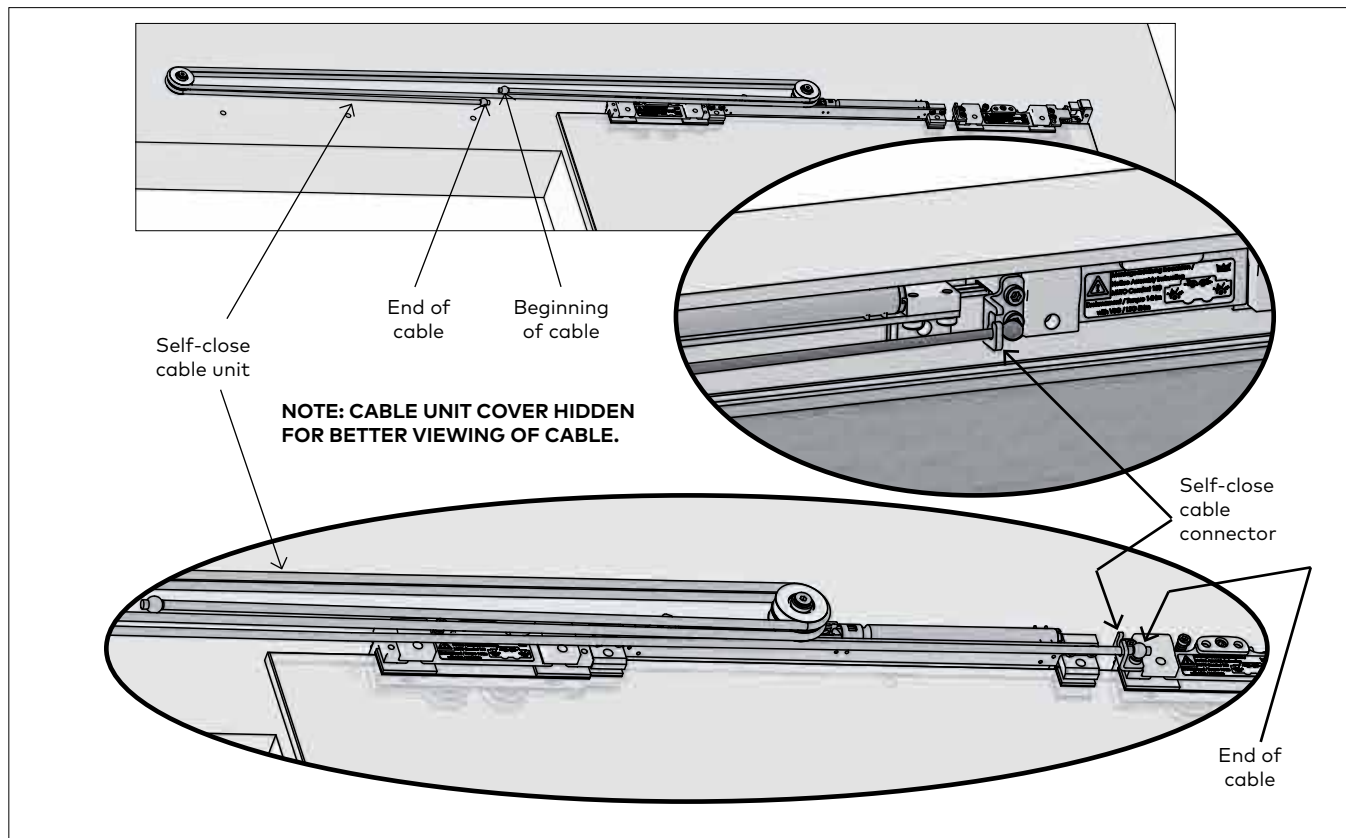

- 2.26.1 Pull "end of cable" over to connect with cable connector.
- 2.25.2 Continue to pull cable through connector to either increase or decrease self-closing tension.

2.27 Self-close unit: Adjust tension in self-close cable unit

Fig. 27

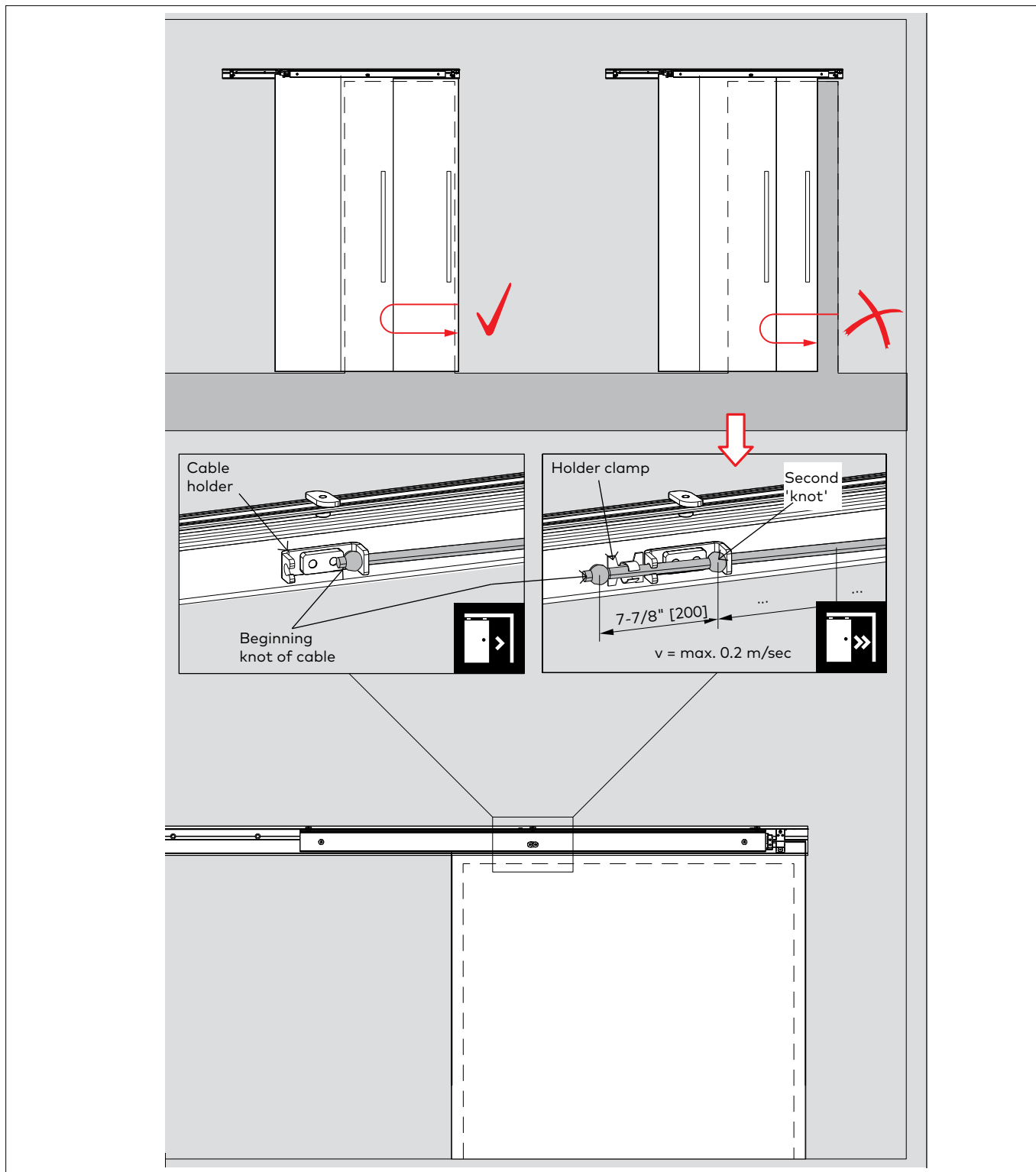

2.27.1 To adjust tension in cable unit cord if necessary, pull 'beginning knot of cable' through cable holder.

2.27.2 Secure another 'knot' and pull cable through holder as show in image above.

2.27.3 Secure beginning 'knot' in holder clamp.

NOTE: Be sure there is a 7-7/8" [200] gap between each new 'knot' in the cord.

2.28 Install cover clips

Fig. 28

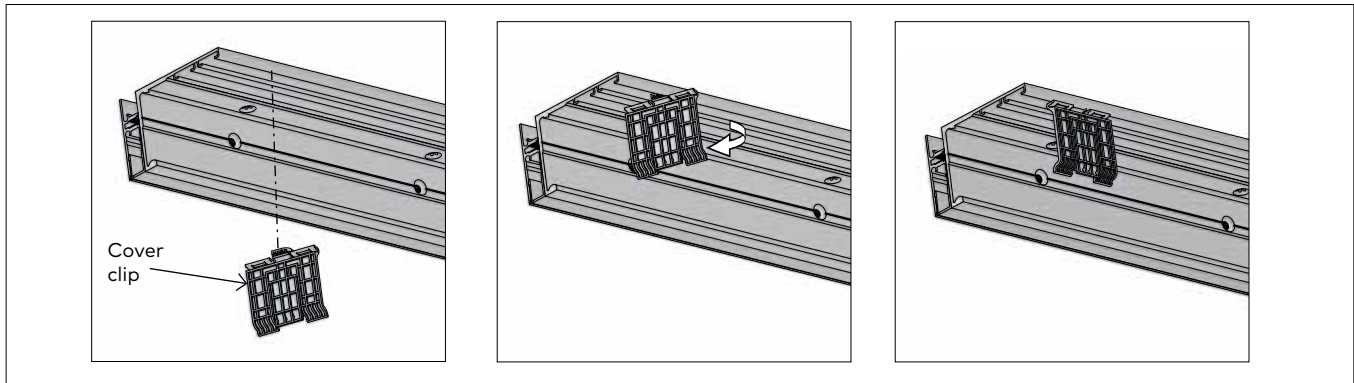

2.28.1 Insert cover clips into track. (One clip per foot)

2.27.2 Insert perpendicular to track, and turn **CLOCKWISE** to snap into place.

2.29 Cover spacers

Fig. 29

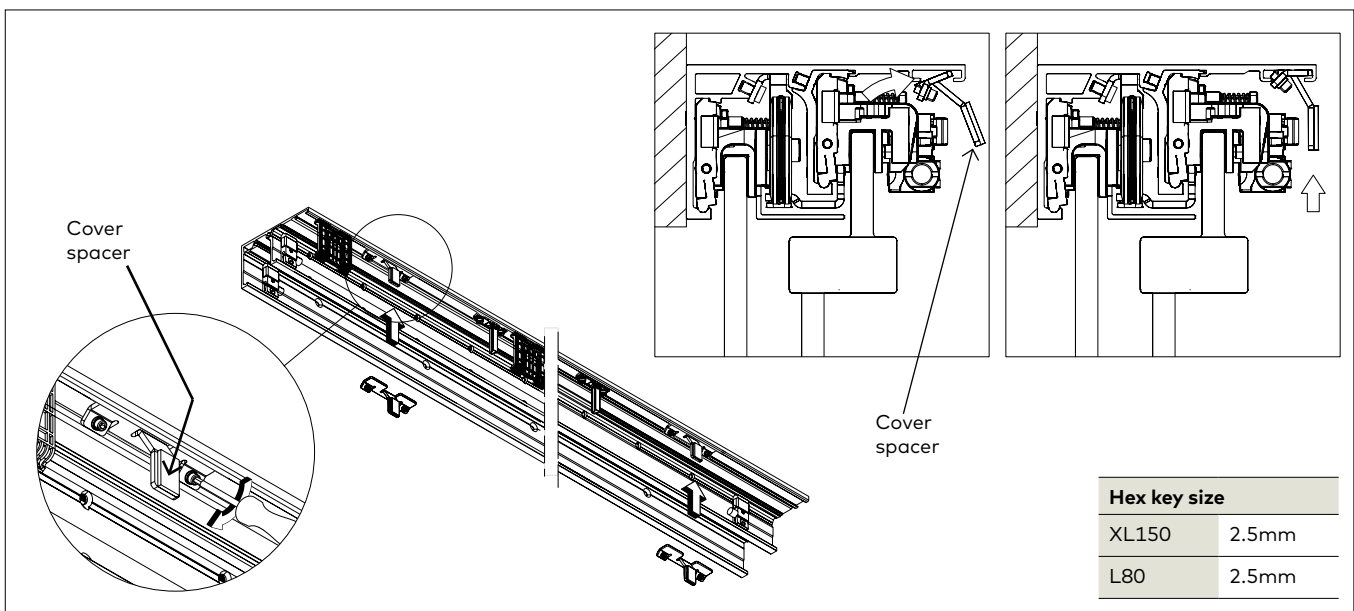

2.29.1 Tip cover spacers into outer most edge of track.

2.28.2 Place one at each end of track as shown.

2.28.3 Tighten at at 0.7 ftl bs [1Nm] or hand tighten.

2.30 Install brush profile

Fig. 30

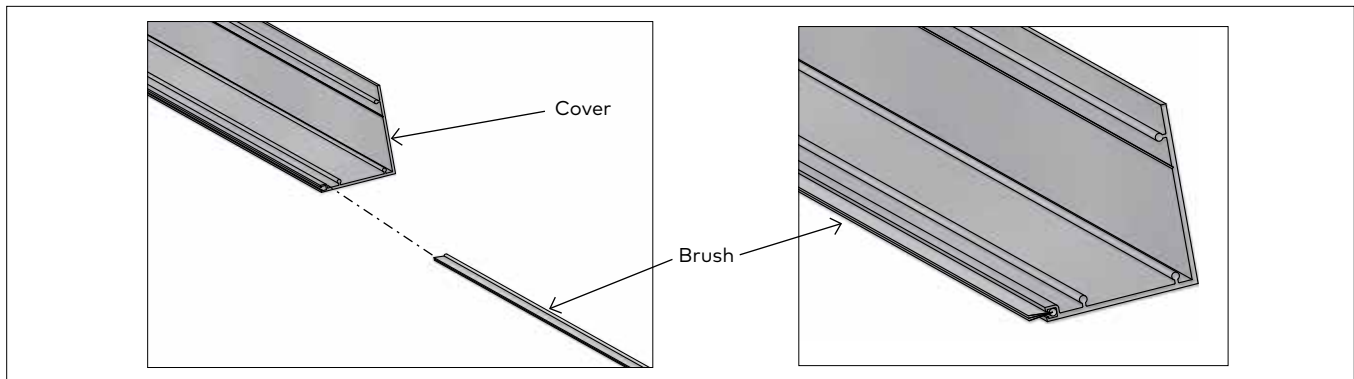

2.30.1 Measure and cut brush to appropriate length.

2.30.2 Slide brush into cover.

2.31 Install view protection clips

Fig. 31

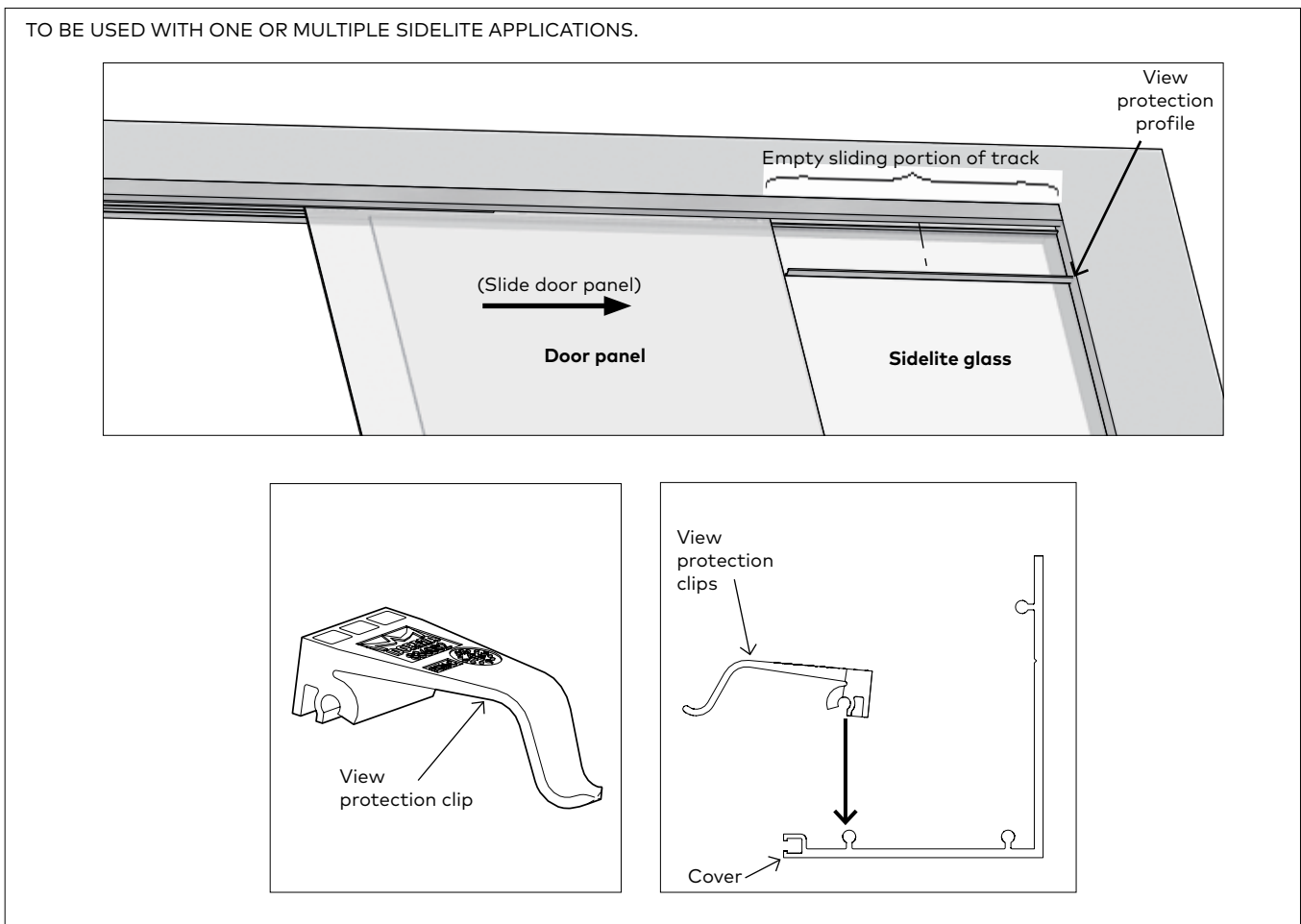

2.31.1 Slide door open until it meets the end stop.

2.31.2 Measure and cut view protection profile to fit into empty sliding portion of track - 3/16" [5].

2.31.3 Snap view protection clips onto inside of cover as shown.

2.31.4 Use minimum 1 clip per foot of profile.

Exception: If profile is minimum of 1 foot in length, use 2 clips.

2.32 Install cover and view protection profile

Fig. 32

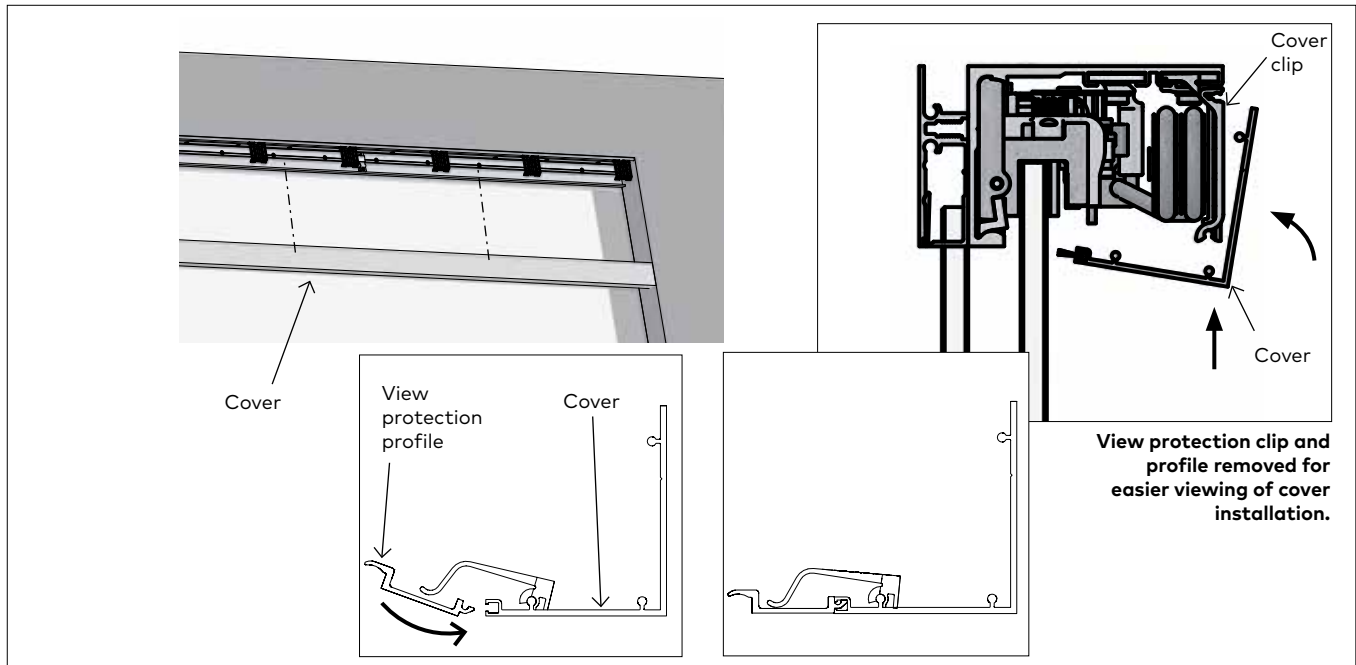

2.32.1 Secure cover to clips and snap into place.
NOTE: Roll cover from the bottom upwards. Ensure the bottom of the cover is supported by the groove in the cover clip.

2.32.2 Tip view protection profile up into track and snap down into cover and onto track as shown.

2.33 Install end caps

Fig. 33

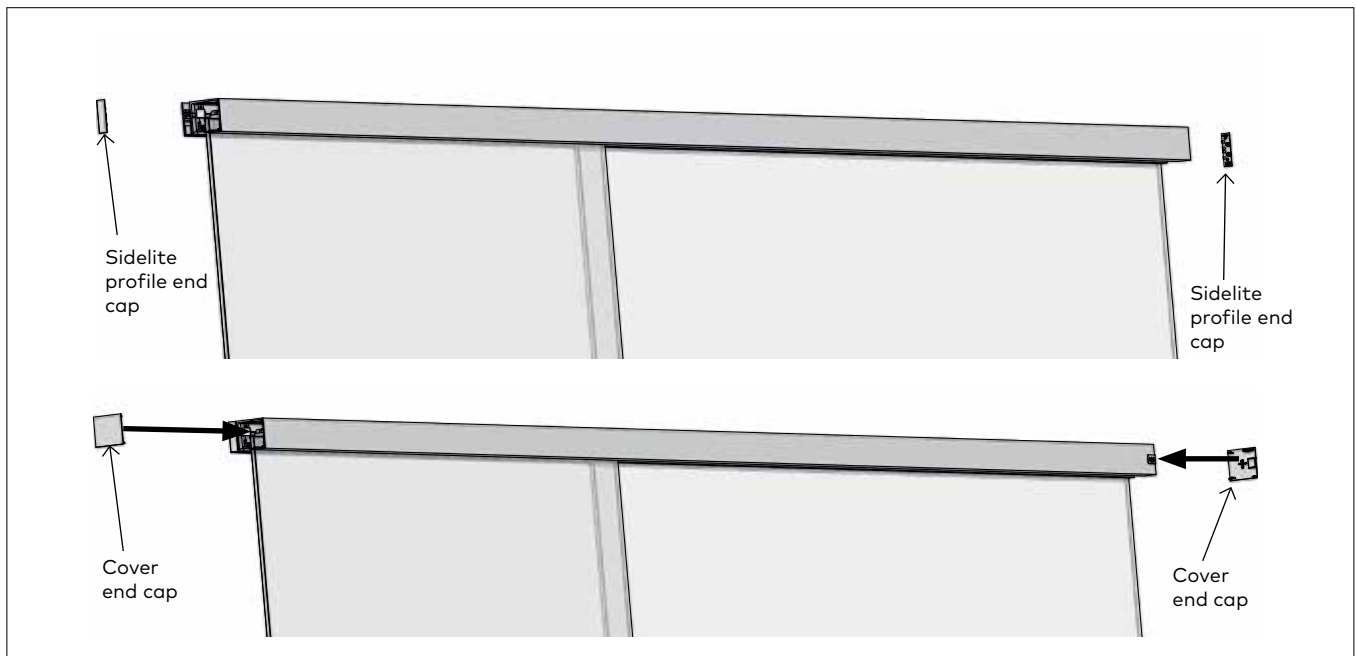

2.33.1 Snap sidelite profile end caps into sidelite profile.

2.33.2 Snap end caps into cover.



Scan for product details and downloads.

Call 800-523-8483 or visit
glasstechserv.us@dormakaba.com
for assistance or warranty information

dormakaba USA, Inc.
1 Dorma Drive, Drawer AC
Reamstown, PA 17567